



Vane Pump SERIES

Table of Contents

V Pumps	3-16
Order Code - Single Pump	3
Order Code - Double Pump	4
Performance Data - 20V	5
Performance Data - 25V	6
Performance Data - 35V	7
Performance Data - 45V	8
Installation Dimension - 20V	9
Installation Dimension - 25V	10
Installation Dimension - 35V	11
Installation Dimension - 45V	12
Installation Dimension - 2520V	13
Installation Dimension - 3520V	14
Installation Dimension - 3525V	15
Installation Dimension - 4520V	16
Installation Dimension - 4525V	17
Installation Dimension - 4535V	18
VQ Pumps	19-34
Order Code - Single Pump	19
Order Code - Double Pump	20
Performance Data - 20VQ	21
Performance Data - 25VQ	22
Performance Data - 35VQ	23
Performance Data - 45VQ	24
Installation Dimension - 20VQ	25
Installation Dimension - 25VQ	26
Installation Dimension - 35VQ	27
Installation Dimension - 45VQ	28
Installation Dimension - 2520VQ	29
Installation Dimension - 3520VQ	30
Installation Dimension - 3525VQ	31
Installation Dimension - 4520VQ	32
Installation Dimension - 4525VQ	33
Installation Dimension - 4535VQ	34
VQSV10 Triple Pumps	35-41
Order Code - Triple Pump	35
Order Specification	36
Installation Dimension - 2520VQSV10	37
Installation Dimension - 3520VQSV10	38
Installation Dimension - 3525VQSV10	39
Installation Dimension - 4525VQSV10	40
Installation Dimension - 4535VQSV10	41
VQH Pumps	42-52
Order Code - Single Pump	42
Order Code - Double Pump	43
Installation Dimension - 25VQH	44
Installation Dimension - 35VQH	45
Installation Dimension - 45VQH	46
Installation Dimension - 2520VQH	47
Installation Dimension - 3520VQH	48
Installation Dimension - 3525VQH	49
Installation Dimension - 4520VQH	50
Installation Dimension - 4525VQH	51
Installation Dimension - 4535VQH	52

Table of Contents

V10-V20 Pumps	53-63
Order Code - Single Pump	53
Order Code - Double Pump	54
Performance Data - V10	55
Performance Data - V20	56
Performance Data - V2010 & V2020 Shaft End	57
Performance Data - V2010 Cover End	58
Performance Data - V2020 Cover End	59
Installation Dimension - V10	60
Installation Dimension - V20	61
Installation Dimension - V2010	62
Installation Dimension - V2020	63
SAE 4-Bolt Flanges	64

(F3) - 25V 17 A - 1 C 22 L

 1 2 3 4 5 6 7 8

1 Special Seals

 Omit - (Standard)
 F3 - Viton Seals

2 Series No

 20V 25V 35V
 45V

3 Pump (GPM)

 (@1200 RPM, 100 PSI)
 20V 25V 35V

2 10 25
 5 12 30
 8 14 32
 9 17 35
 11 19 38
 12 21
 14

45V

 42
 45
 50
 60
 75

4 Port Connection

 A - SAE 4-Bolt Flange (Standard)

5 Shaft Type

 1 - Straight Keyed (Standard)
 151 - Splined
 (20V Only)
 11 - Splined
 86 - Straight Keyed
 (Heavy Duty Except 20V)

6 Outlet Port Position

 (View From Cover End of Pump)
 A - Opposite Inlet
 B - 90° CCW From Inlet
 C - Inline With Inlet (Standard)
 D - 90° CW From Inlet

7 Design Number

 22 - (Standard)
 10 - Design Change

8 Rotation

 (View From Shaft End of Pump)
 Omit - Right Hand Rotation
 (Standard)
 L - Left Hand Rotation



SERIES NO	PUMP (GPM)	MAX SPEED (RPM)			MAX PRESSURE (PSI)			MIN SPEED (RPM)				
		ANTI-WEAR OIL	WATER GLYCOL	WATER-IN-OIL EMULSION	ANTI-WEAR OIL	WATER GLYCOL	WATER-IN-OIL EMULSION	ALL FLUIDS				
20V	2	1800	1500	1200	2000	2000	1000	600				
	5,8,9,11				3000	2300	1000					
	12				2300	2000	1000					
	14				2000	2000	1000					
25V	10,12,14,17,19,21								2500	2300	1000	
35V	25,30,32,35,38								2500	2300	1000	
45V	42,45,50,60								2500	2300	1000	
	75								2000	2000	1000	

(F3) - 2520V 17 A 11 - 1 C C 22 L

 1 2 3 4 5 6 7 8 9 10

1 Special Seals

Omit - (Standard)
 F3 - Viton Seals

2 Series No

2520V 3520V 3525V
 4520V 4525V 4535V

3 Shaft End Pump (GPM)

(@1200 RPM, 100 PSI)

25**V 35**V 45**V

 10 25 42
 12 30 45
 14 32 50
 17 35 60
 19 38 75
 21

4 Port Connection

A - SAE 4-Bolt Flange (Standard)

5 Cover End Pump (GPM)

(@1200 RPM, 100 PSI)

**20V **25V **35V

 2 10 25
 5 12 30
 8 14 32
 9 17 35
 11 19 38
 12 21
 14

6 Shaft Type

1 - Straight Keyed (Standard)
 11 - Splined
 86 - Straight Keyed (Heavy Duty)

7 Outlet No 1 Port Position

(View From Cover End of Pump)

A - Opposite Inlet
 B - 90° CCW From Inlet
 C - Inline With Inlet (Standard)
 D - 90° CW From Inlet

8 Outlet No 2 Port Position

(View From Cover End of Pump)
 All Series Except 4535V

A - 135° CCW From Inlet
 B - 45° CCW From Inlet
 C - 45° CW From Inlet (Standard)
 D - 135° CW From Inlet

Series 4535V

A - Opposite Inlet
 B - 90° CCW From Inlet
 C - Inline with Inlet (Standard)
 D - 90° CW From Inlet

9 Design Number

22 - (Standard)
 10 - Design Change

10 Rotation

(View From Shaft End of Pump)
 Omit - Right Hand Rotation
 (Standard)
 L - Left Hand Rotation

NOTE: See Respective Pump Performance in V Pump Performance for Double Pump Performance.



SERIES NO	PUMP (GPM)	MAX SPEED (RPM)			MAX PRESSURE (PSI)			MIN SPEED (RPM)												
		ANTI-WEAR OIL	WATER GLYCOL	WATER-IN-OIL EMULSION	ANTI-WEAR OIL	WATER GLYCOL	WATER-IN-OIL EMULSION	ALL FLUIDS												
**20V	2	1800	1500	1200	2000	2000	1000	600												
	5,8,9,11				3000	2300	1000													
	12				2300	2000	1000													
	14				2000	2000	1000													
25**V	10,12,14,17,19,21				1800	1500	1200		2500	2300	1000	600								
**25V									2500	2300	1000									
35**V	25,30,32,35,38								1800	1500	1200		2500	2300	1000	600				
**35V													2500	2300	1000					
45**V	42,45,50,60												1800	1500	1200		2500	2300	1000	600
	75																2000	2000	1000	

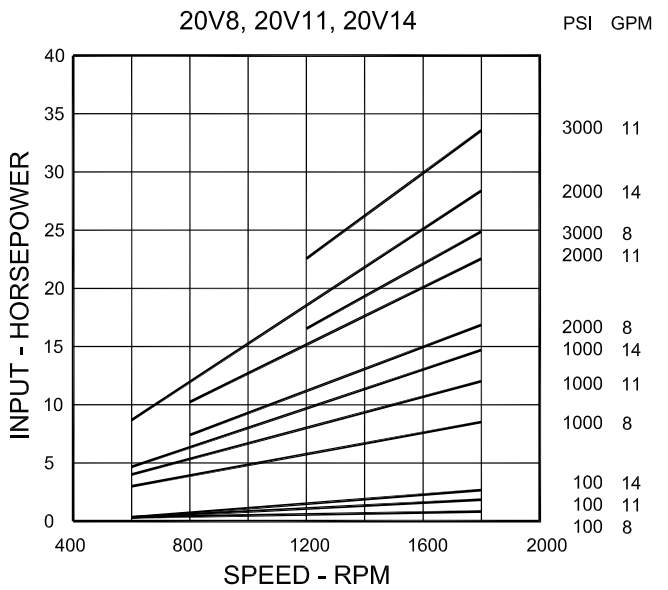
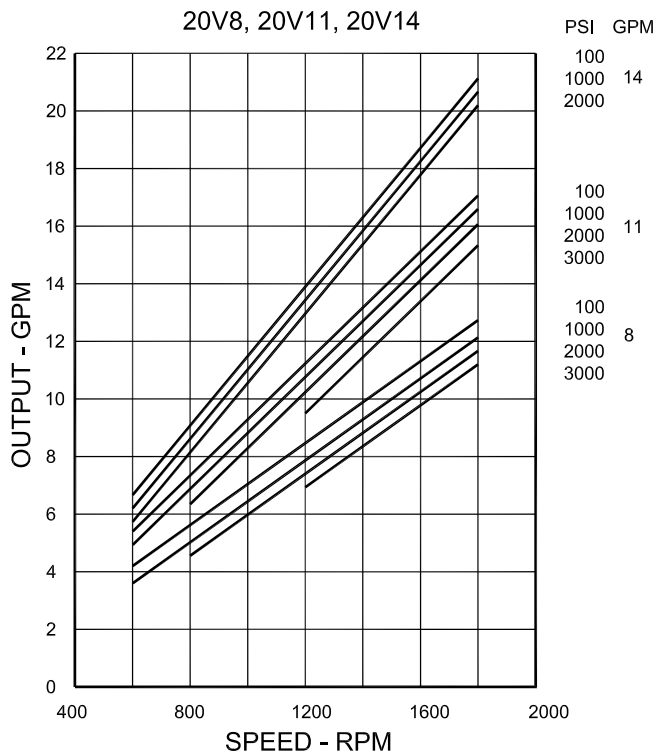
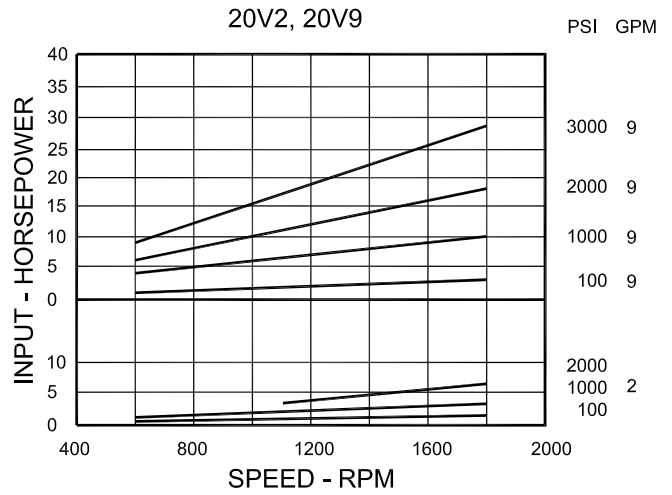
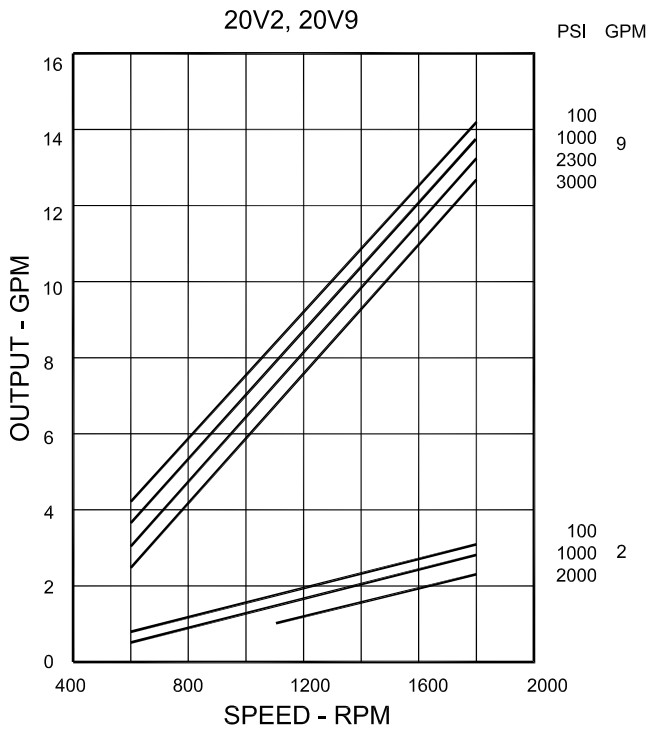

Data Based on SAE 10W Fluid @ 120°F and Pump Inlet @ 0 PSIG (14.7 PSIA)

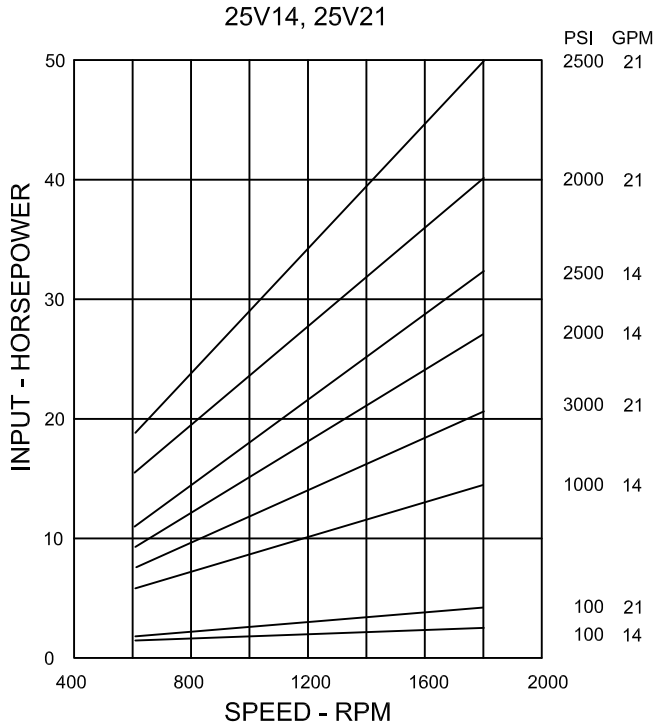
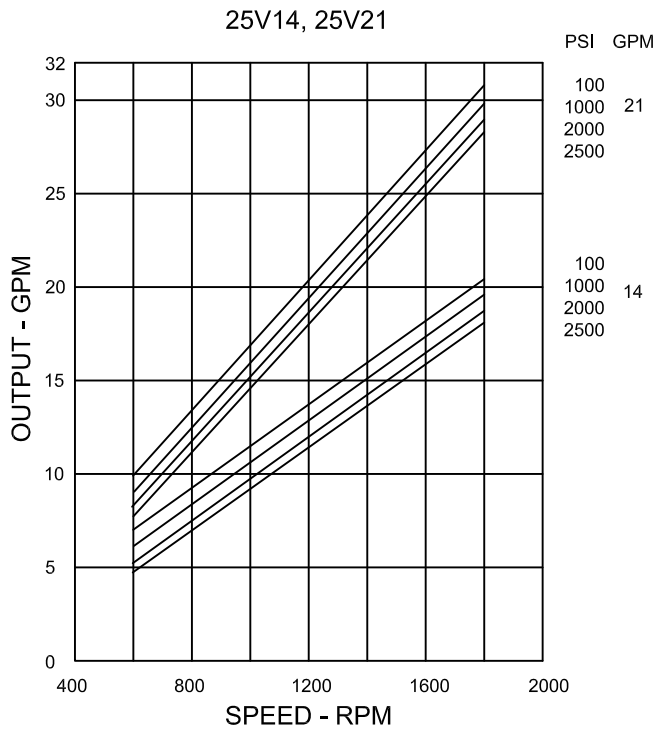
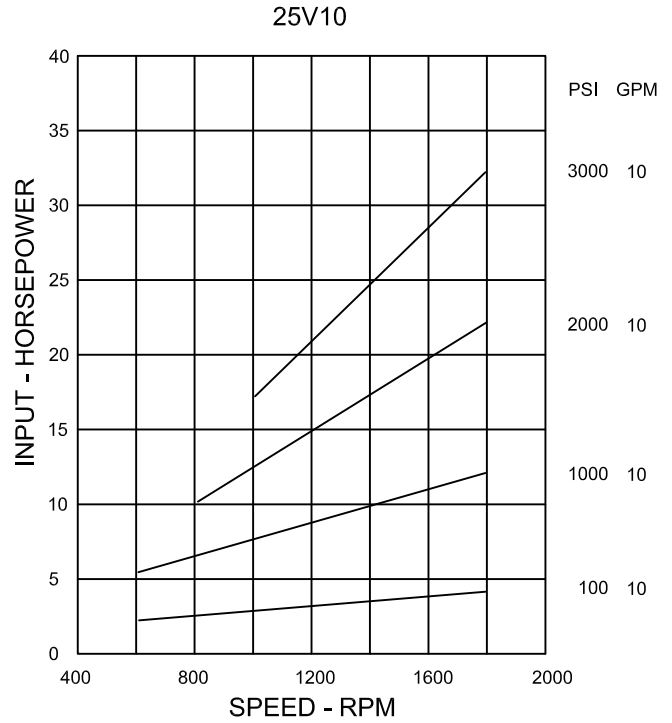
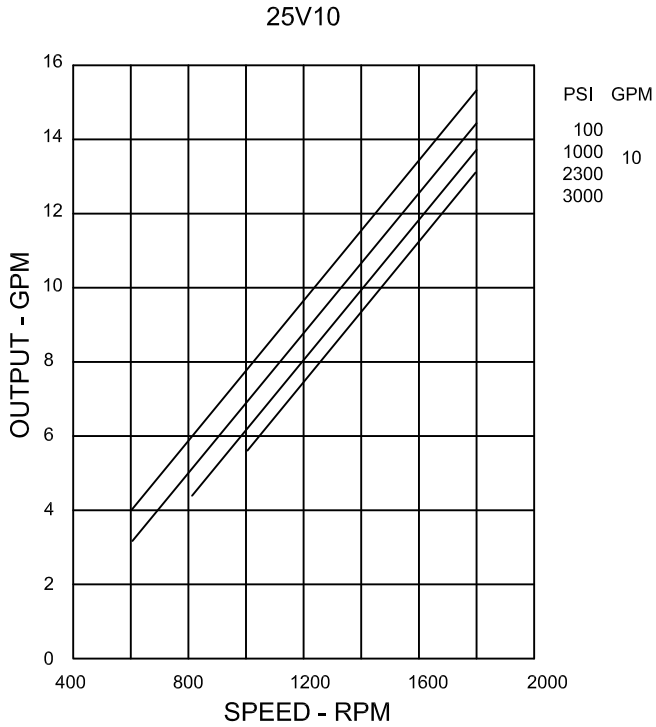

Data Based on SAE 10W Fluid @ 120°F and Pump Inlet @ 0 PSIG (14.7 PSIA)

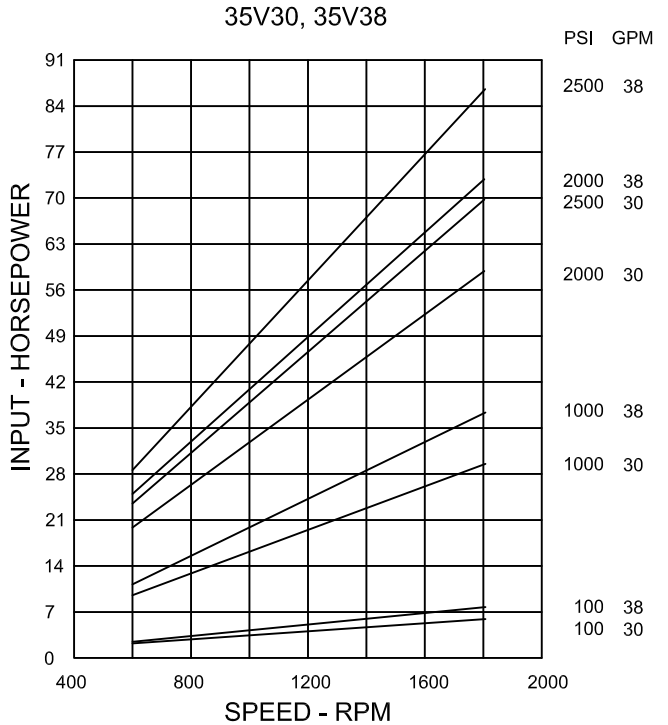
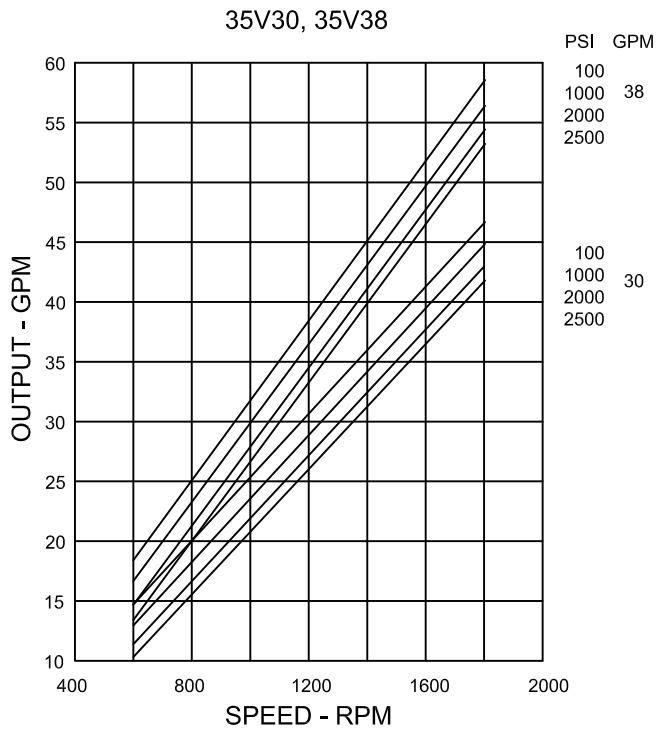
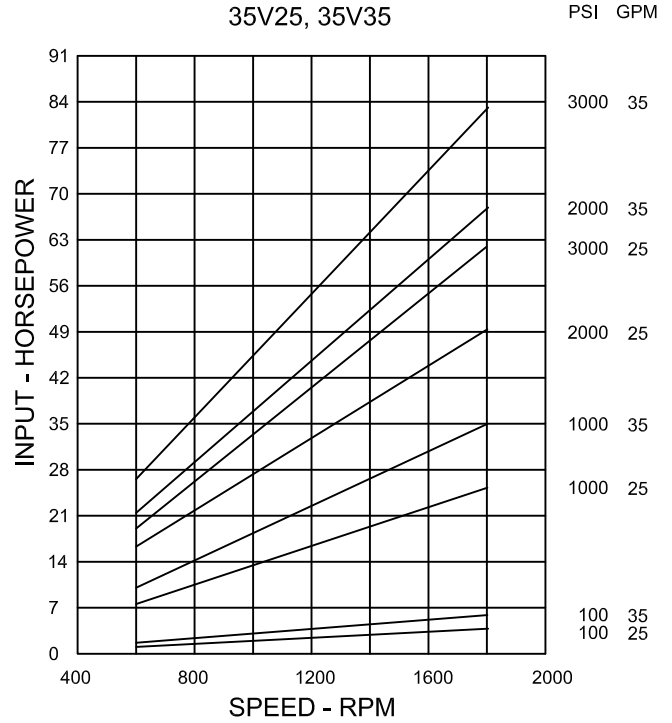
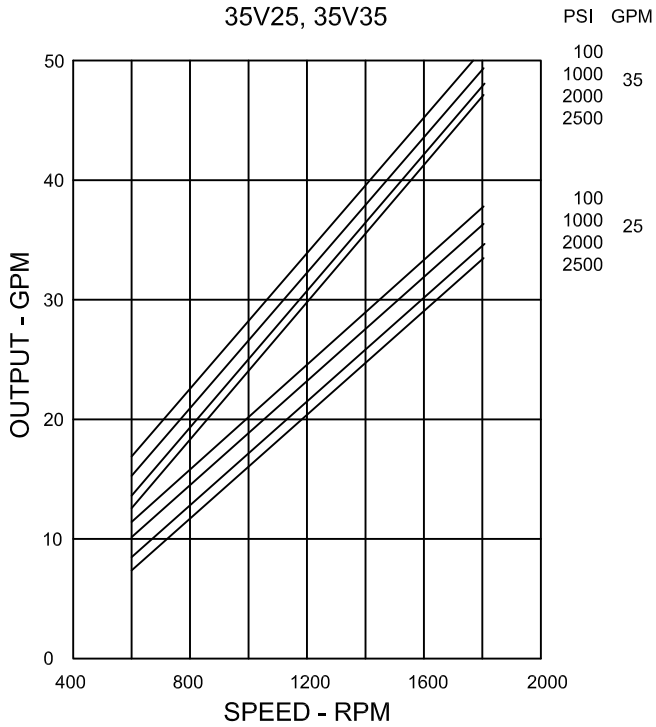

Data Based on SAE 10W Fluid @ 120°F and Pump Inlet @ 0 PSIG (14.7 PSIA)

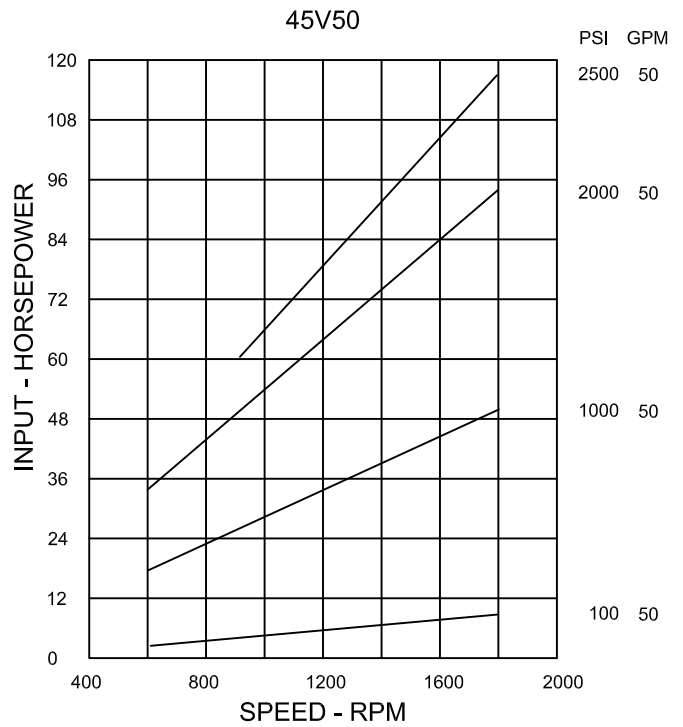
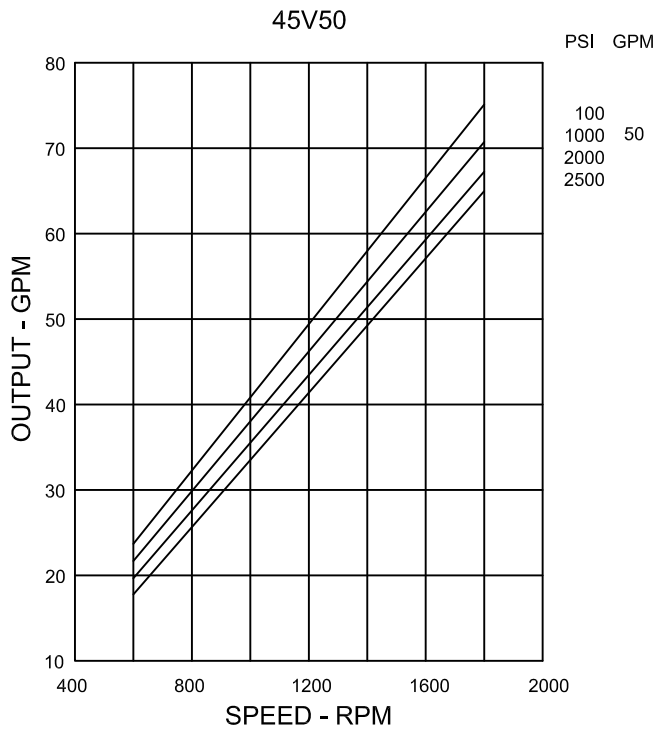
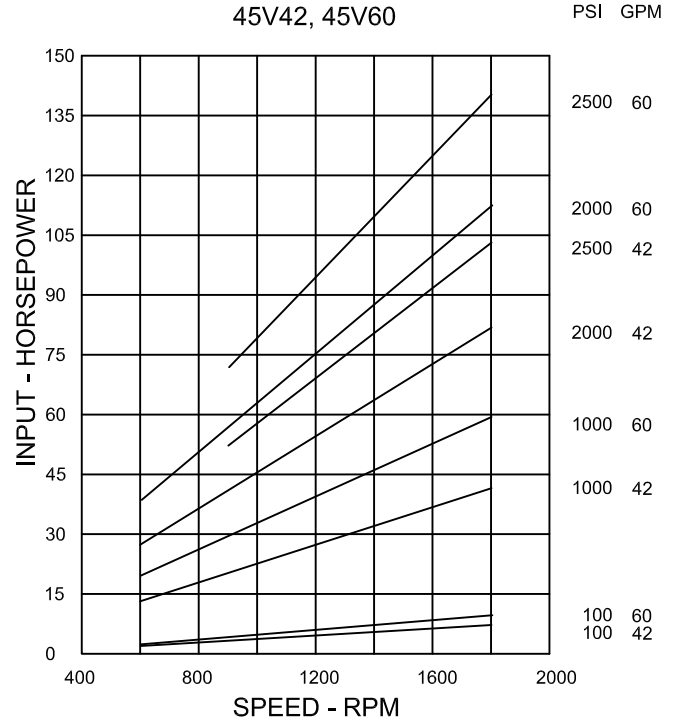
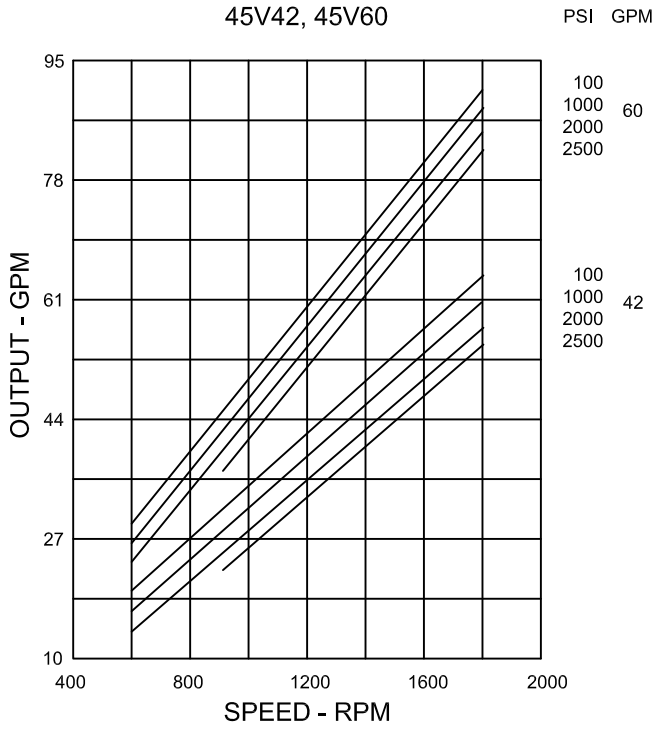

Data Based on SAE 10W Fluid @ 120°F and Pump Inlet @ 0 PSIG (14.7 PSIA)

20V INSTALLATION DIMENSION

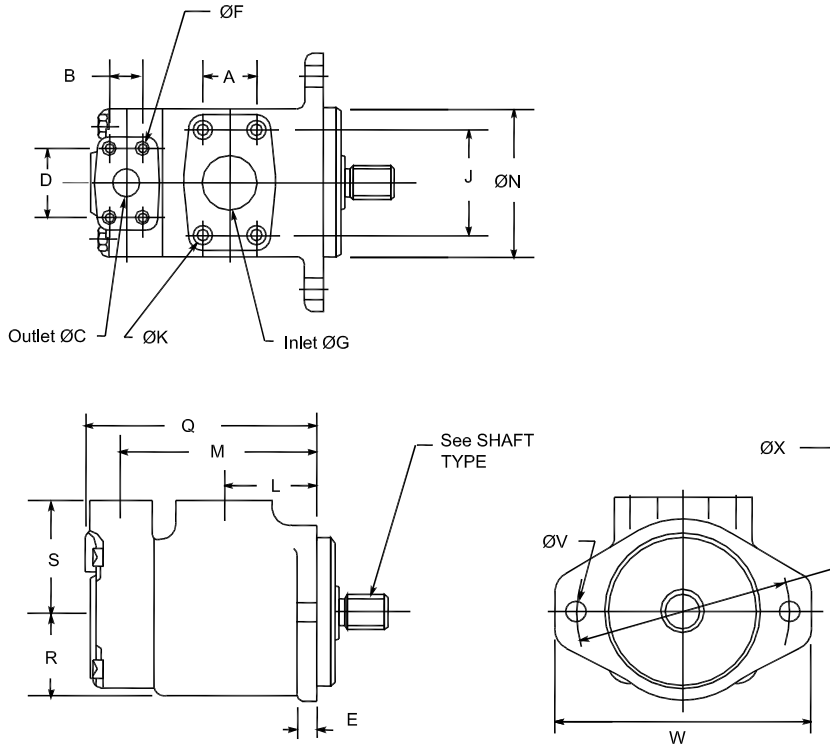

SHAFT TYPE

#1 Straight Shaft

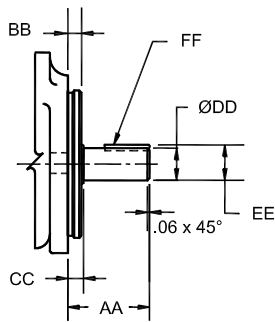

#151 Splined Shaft

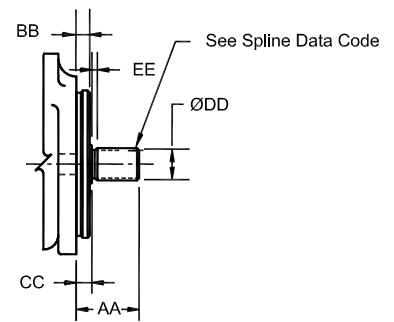

	A	B	ØC	D	E	ØG	J	L	M	ØN
BODY	1.41	0.875	0.75	1.87	0.50	1.50	2.75	2.5	5.22	4.000/3.998
	Q	R	S	ØV x 2	W	ØX				
	6.12	2.2	3.00	0.56	6.875	5.75				
PORT CONN.	ØF x 4 Holes			ØK x 4 Holes			Outlet Flange		Inlet Flange	
	3/8"-16UNC-2B x 0.75			1/2"-13UNC-2B x 0.83			F1-6-		F1-12-	
SHAFT TYPE	Shaft Type	AA	BB	CC	ØDD	EE	FF Key Width x Length			
	1	2.32	.375	.476	.875/.874	.966/.961	.187x1.25			
	Shaft Type	AA	BB	CC	ØDD	EE	Spline Data Code			
	151	1.62	.375	.437	1.09	.156	A (See Below Chart)			
	Spline Data Code	Number of Teeth	Pitch	Major Diameter	Form Diameter	Minor Diameter	Minor Diameter			
	A	13	16/32	.873/.872	.749	.734/.723	Major dia. fit			

25V INSTALLATION DIMENSION

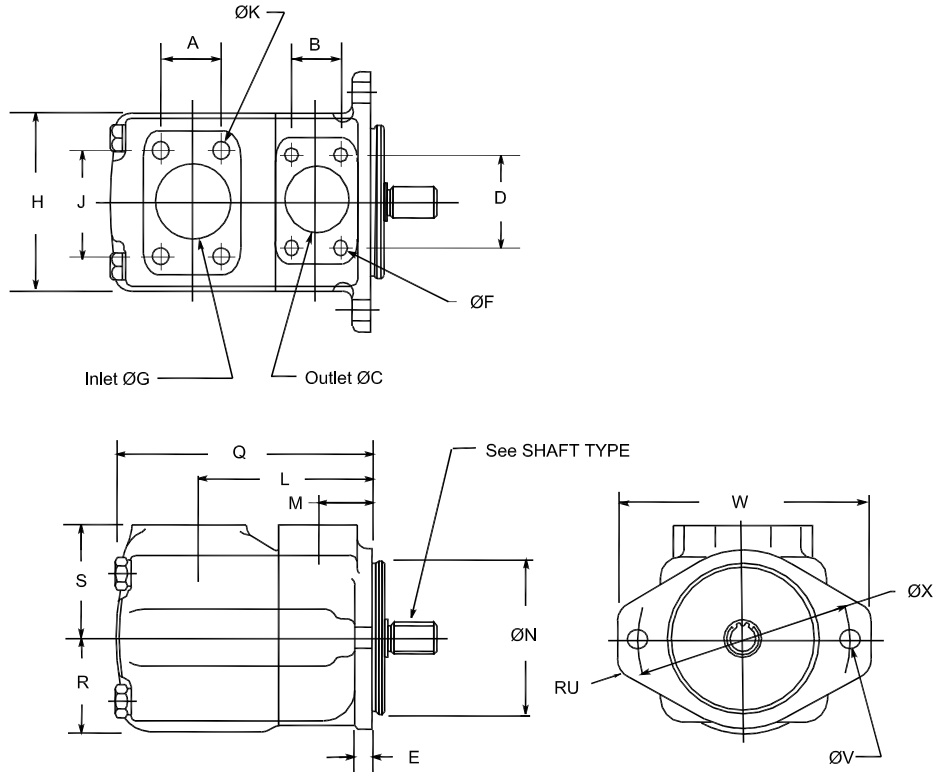

SHAFT TYPE

#1 Straight Shaft

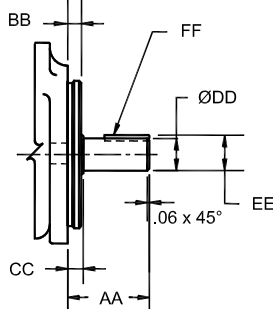

#11 Splined Shaft

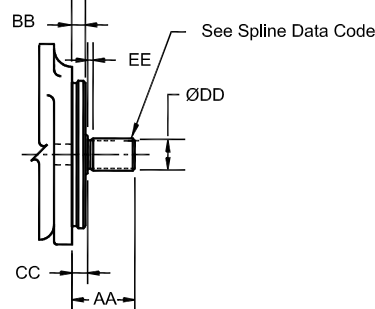

#86 Straight Shaft

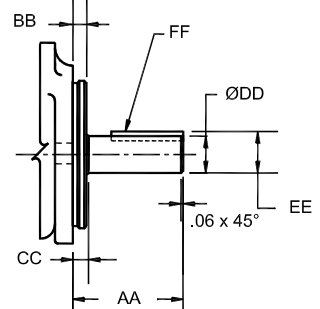

BODY	A	B	ØC	D	E	ØG	H	J	L	M	ØN
	1.41	1.03	1.00	2.06	0.50	1.50	4.62	2.75	4.76	1.50	4.000/3.998
PORT CONN.	ØF x 4 Holes		ØK x 4 Holes		Outlet Flange		Inlet Flange				
	3/8"-16UNC-2B x 0.75		1/2"-13UNC-2B x 0.94		F1-8-		F1-12-				
SHAFT TYPE	Shaft Type	AA	BB	CC	ØDD	EE	FF Key Width x Length				
	1	2.32	.375	.437	.875/.874	.966/.961	.187x1.25				
	86	3.06	.375	.437	.999/.998	1.11/1.10	.250x2.00				
	Shaft Type	AA	BB	CC	ØDD	EE	Spline Data Code				
11	1.75	.375	.437	1.09	.156	A (See Below Chart)					
Spline Data Code	Number of Teeth	Pitch	Major Diameter	Form Diameter	Minor Diameter	Minor Diameter					
A	13	16/32	.873/.872	.749	.734/.723	Major dia. fit					

35V INSTALLATION DIMENSION

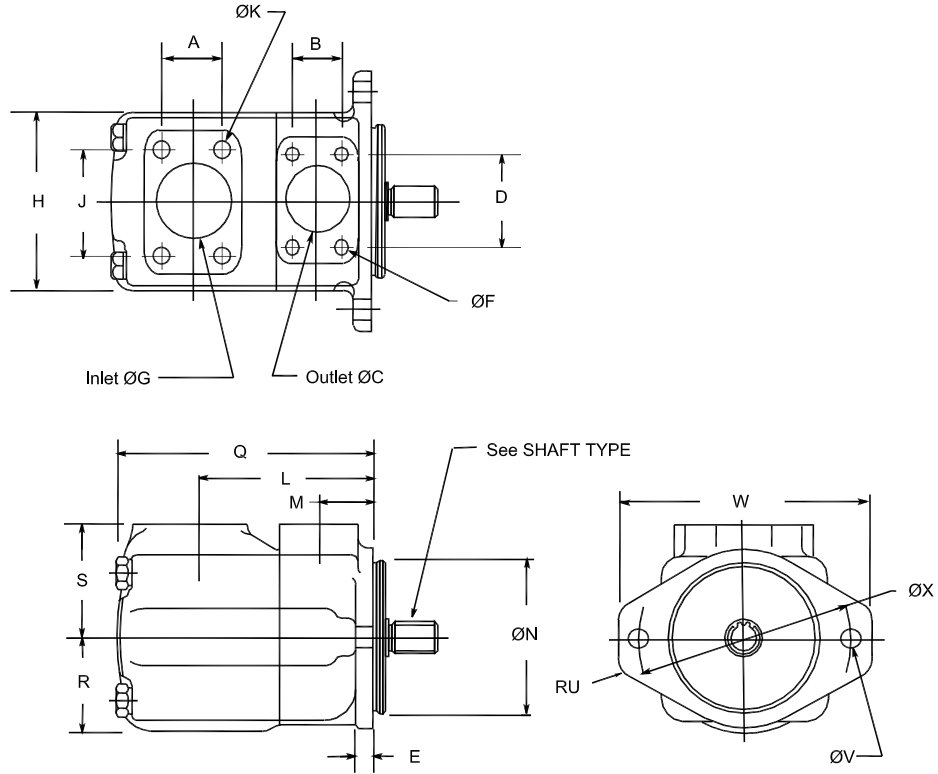

SHAFT TYPE

#1 Straight Shaft

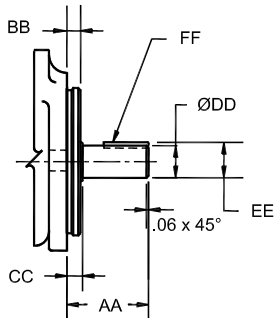

#11 Splined Shaft

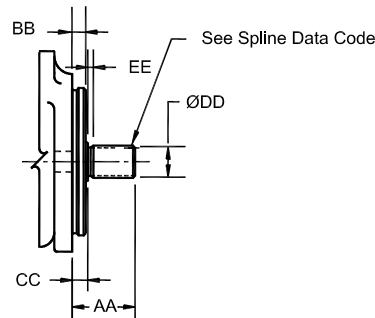

#86 Straight Shaft

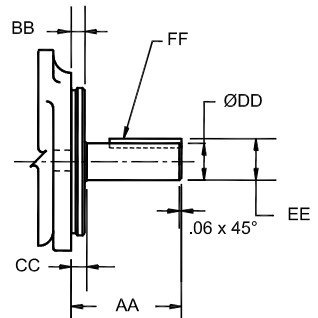

	A	B	ØC	D	E	ØG	H	J	L	M	ØN	
BODY	1.69	1.19	1.25	2.31	0.63	2.00	5.50	3.06	4.94	1.50	5.000/4.998	
	Q	R	S	RU	ØV x 2	W	ØX					
	7.28	2.75	3.25	0.63	0.69	8.38	7.13					
PORT CONN.	ØF x 4 Holes		ØK x 4 Holes		Outlet Flange		Inlet Flange					
	7/16"-14UNC-2B x 0.88		1/2 "-13UNC-2B x 0.88		F1-10-		F1-16-					
SHAFT TYPE	Shaft Type	AA	BB	CC	ØDD	EE	FF Key Width x Length					
	1	2.88	.375	.437	1.250/1.248	1.392/1.382	.313x1.50					
	86	3.88	.375	.437	1.374/1.373	1.518/1.508	.312x2.13					
	Shaft Type	AA	BB	CC	ØDD	EE	Spline Data Code					
	11	2.31	.375	.437	1.38	.25	D (See Below Chart)					
Spline Data Code	Number of Teeth	Pitch	Major Diameter	Form Diameter	Minor Diameter	Minor Diameter						
D	14	12/24	1.248/1.247	1.07	1.063/1.050	Major dia. fit						

45V INSTALLATION DIMENSION

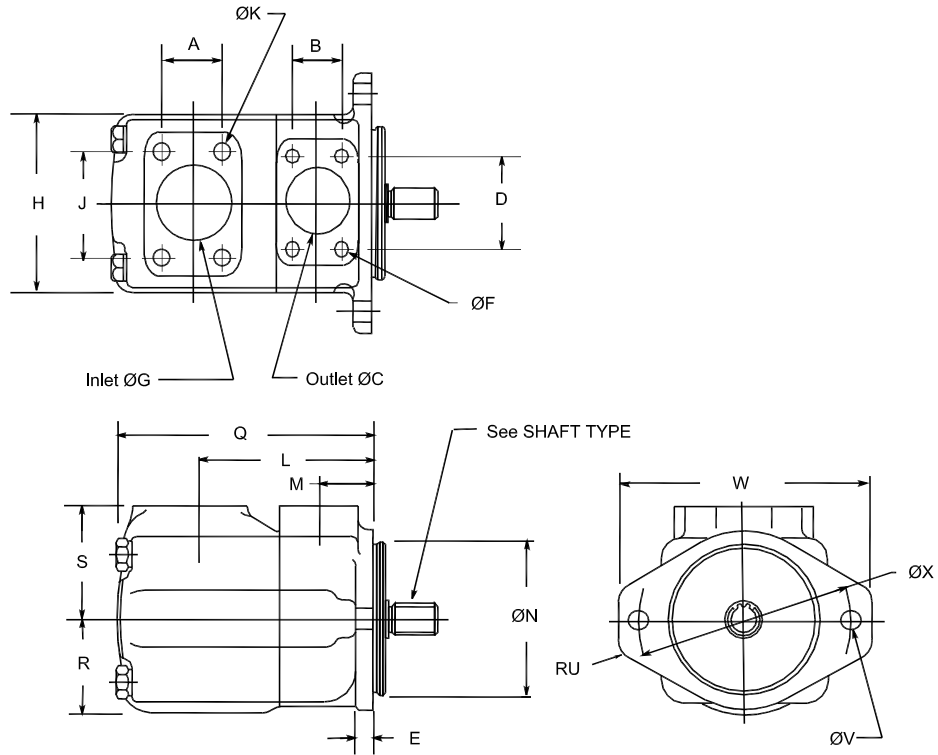

#1 Straight Shaft

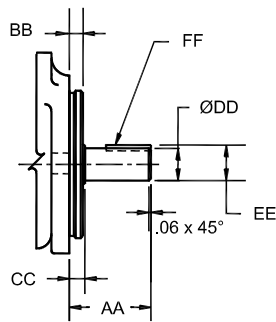

#11 Splined Shaft

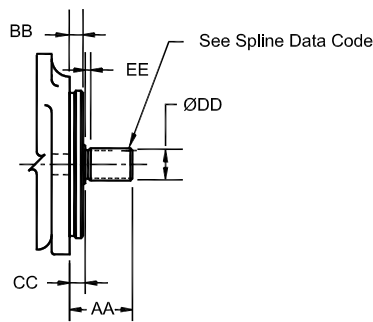

#86 Straight Shaft

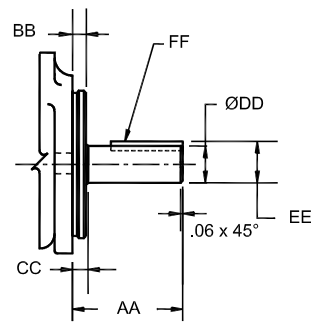

SHAFT TYPE

	A	B	ØC	D	E	ØG	H	J	L	M	ØN	
BODY	2.43	1.41	1.50	2.75	0.63	3.00	6.25	4.19	6.03	1.69	5.000/4.998	
	Q	R	S	RU	ØV x 2	W	ØX					
	8.50	3.25	3.69	0.63	0.69	8.38	7.13					
PORT CONN.	ØF x 4 Holes			ØK x 4 Holes			Outlet Flange		Inlet Flange			
	1/2"-13UNC-2B x 0.94			5/8 "-11UNC-2B x 1.18			F1-12-		F1-24-			
SHAFT TYPE	Shaft Type	AA	BB	CC	ØDD	EE	FF Key Width x Length					
	1	2.44	.500	.560	1.250/1.248	1.390/1.380	.312x1.12					
	86	3.44	.500	.560	1.499/1.498	1.669/1.659	.375x2.00					
	Shaft Type	AA	BB	CC	ØDD	EE	Spline Data Code					
	11	2.44	.500	.565	1.56	.38	D (See Below Chart)					
Spline Data Code	Number of Teeth	Pitch	Major Diameter	Form Diameter	Minor Diameter	Minor Diameter						
D	14	12/24	1.248/1.247	1.07	1.063/1.050	Major dia. fit						

2520V INSTALLATION DIMENSION

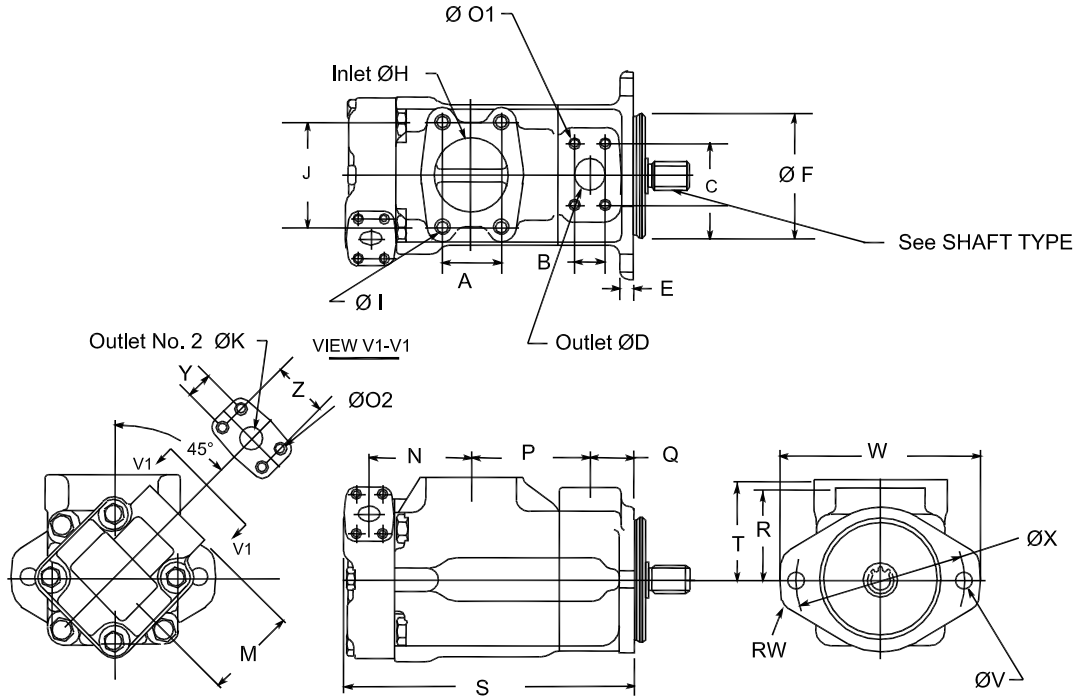

#1 Straight Shaft

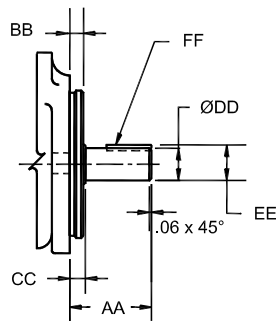

#11 Splined Shaft

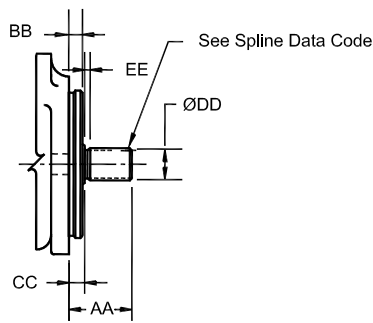

#86 Straight Shaft

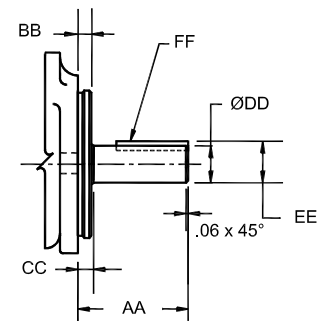

	A	B	C	øD	E	øF	øH	J	øK	M	N	P	Q	R	
BODY	2.00	1.03	2.06	1.00	0.50	4.000/3.998	2.50	3.50	0.75	3.00	3.47	4.00	1.50	3.00	
	S	T	øV x 2	RW	W	øX	Y	Z							
	9.94	3.31	0.56	0.55	6.88	5.75	0.88	1.88							
PORT CONN.	ØO1 x 4 Holes			ØO2 x 4 Holes			ØI x 4 Holes			Outlet No 1 Flange		Outlet No 2 Flange		Inlet Flange	
	3/8"-16UNC-2B x 0.75			3/8"-16UNC-2B x 0.75			1/2"-13UNC-2B x 0.94			F1-8-		F1-6-		F1-20-	
SHAFT TYPE	Shaft Type	AA	BB	CC	øDD	EE	FF Key Width x Length								
	1	2.32	.375	.437	.875/.874	.966/.961	.187x1.25								
	86	3.06	.375	.437	.999/.998	1.11/1.10	.250x2.00								
	Shaft Type	AA	BB	CC	øDD	EE	Spline Data Code								
11	1.75	.375	.437	1.09	.156	A (See Below Chart)									
Spline Data Code	Number of Teeth	Pitch	Major Diameter	Form Diameter	Minor Diameter	Minor Diameter									
A	13	16/32	.873/.872	.749	.734/.723	Major dia. fit									

3520V INSTALLATION DIMENSION

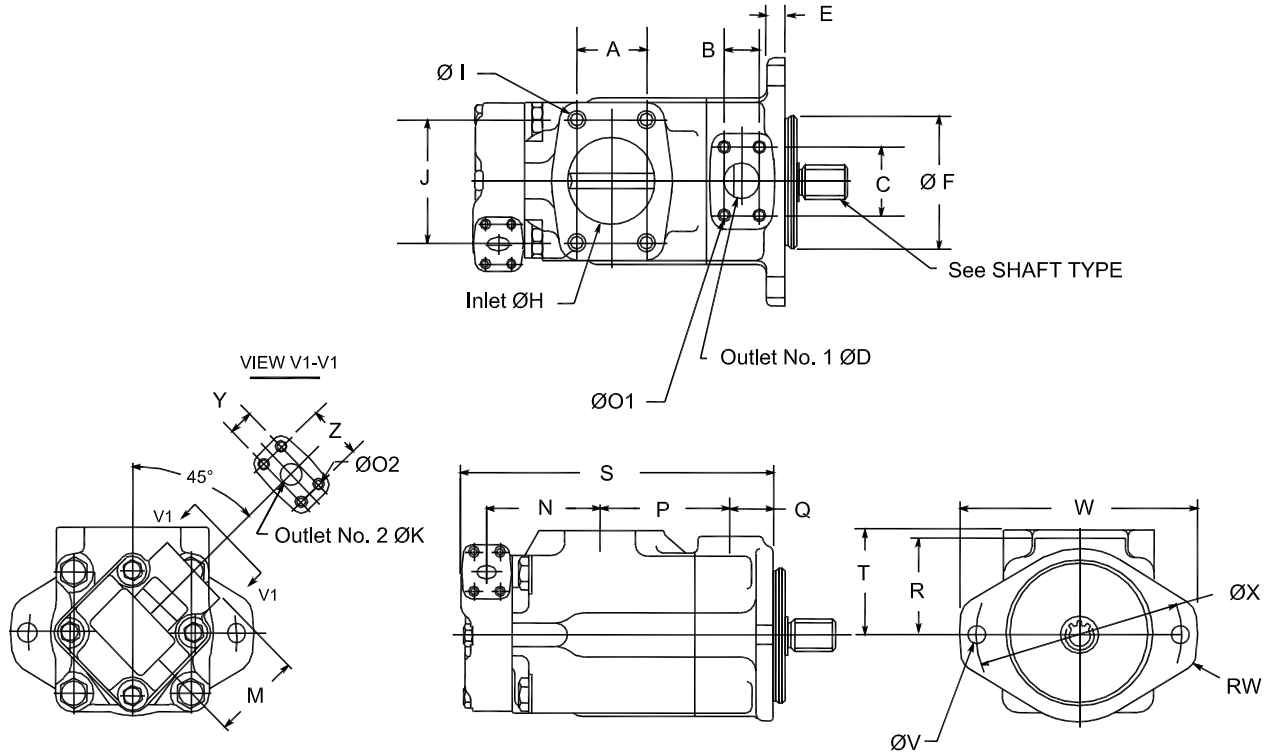

SHAFT TYPE

#1 Straight Shaft

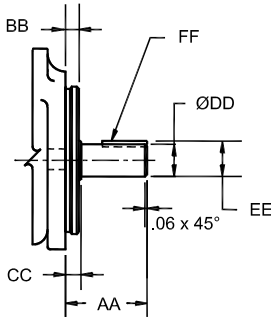

#11 Splined Shaft

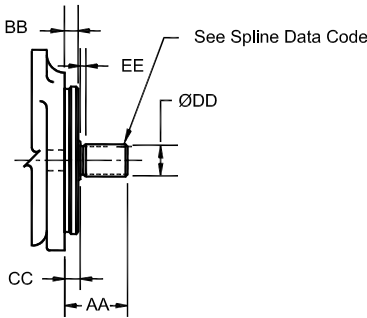

#86 Straight Shaft

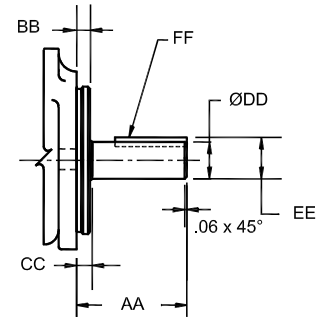

	A	B	C	ØD	E	ØF	ØH	J	ØK	M	N	P	Q	R	
BODY	2.44	1.19	2.31	1.25	0.62	5.000/4.998	3.00	4.19	0.75	3.00	3.92	4.50	1.50	3.25	
	S	T	ØV x 2	RW	W	ØX	Y	Z							
	10.9	3.50	0.69	0.63	8.38	7.13	0.88	1.88							
PORT CONN.	ØO1 x 4 Holes			ØO2 x 4 Holes			Ø I x 4 Holes			Outlet No 1 Flange		Outlet No 2 Flange		Inlet Flange	
	7/16"-14UNC-2B x 0.88			3/8"-16UNC-2B x 0.75			5/8"-11UNC-2B x 1.125			F1-10-		F1-6-		F1-24-	
SHAFT TYPE	Shaft Type	AA	BB	CC	ØDD	EE	FF Key Width x Length								
	1	2.88	.375	.437	1.250/1.248	1.392/1.382	.313x1.50								
	86	3.88	.375	.437	1.374/1.373	1.518/1.508	.312x2.13								
	Shaft Type	AA	BB	CC	ØDD	EE	Spline Data Code								
11	2.31	.375	.437	1.38	.25	D (See Below Chart)									
Spline Data Code	Number of Teeth	Pitch	Major Diameter	Form Diameter	Minor Diameter	Minor Diameter									
D	14	12/24	1.248/1.247	1.07	1.063/1.050	Major dia. fit									

3525V INSTALLATION DIMENSION

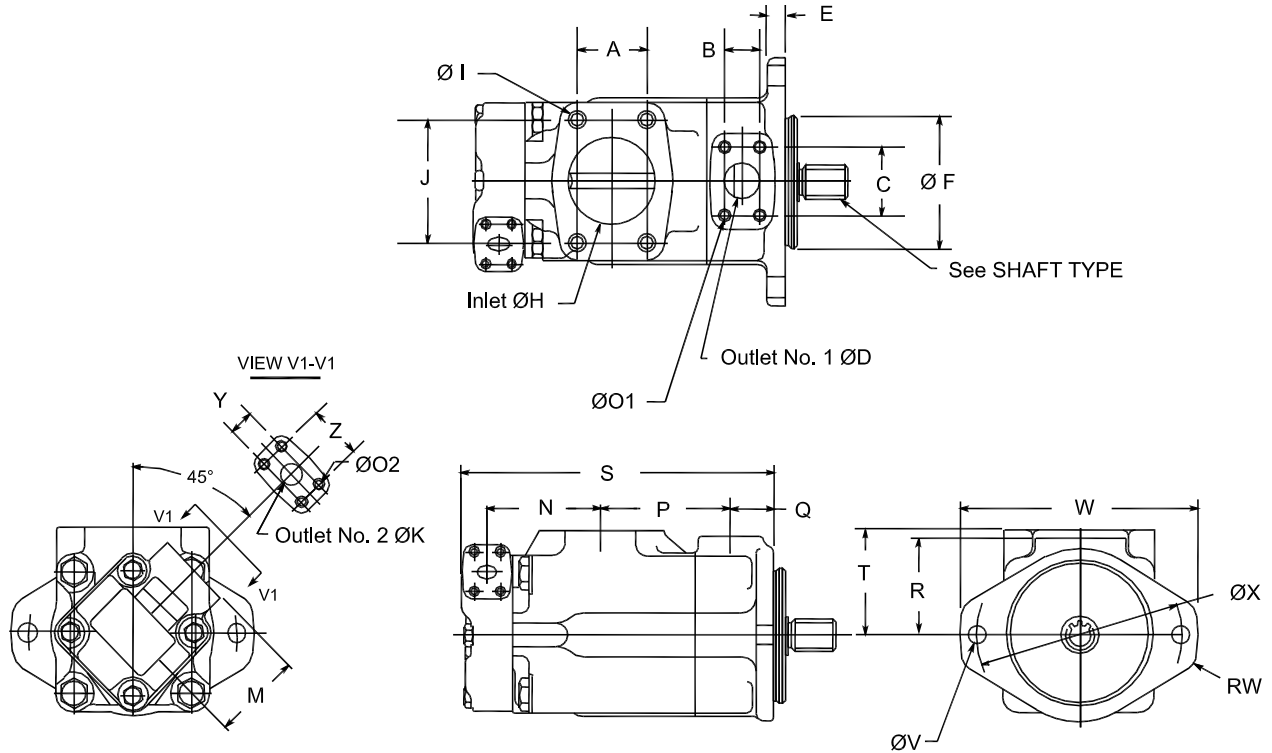

#1 Straight Shaft

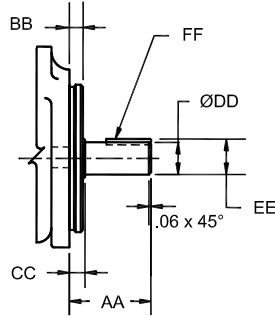

SHAFT TYPE

#11 Splined Shaft

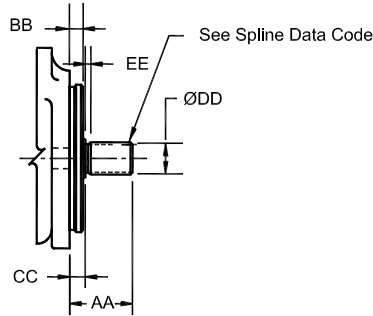

#86 Straight Shaft

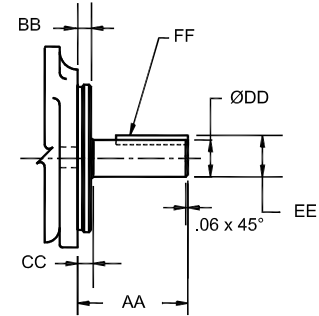

BODY	A	B	C	øD	E	øF	øH	J	øK	M	N	P	Q	R
		2.44	1.19	2.31	1.25	0.62	5.000/4.998	3.00	4.19	1.00	2.94	4.31	4.50	1.50
PORT CONN.	S	T	øV x 2	RW	W	øX	Y	Z						
	11.57	3.50	0.69	0.63	8.38	7.13	1.03	2.06						
SHAFT TYPE	øO1 x 4 Holes		øO2 x 4 Holes		øI x 4 Holes			Outlet No 1 Flange		Outlet No 2 Flange		Inlet Flange		
	7/16"-14UNC-2B x 0.88		3/8"-16UNC-2B x 0.66		5/8"-11UNC-2B x 1.125			F1-10-		F1-8-		F1-24-		
	Shaft Type	AA	BB	CC	øDD	EE	FF Key Width x Length							
	1	2.88	.375	.437	1.250/1.248	1.392/1.382	.313x1.50							
86	3.88	.375	.437	1.374/1.373	1.518/1.508	.312x2.13								
Shaft Type	AA	BB	CC	øDD	EE	Spline Data Code								
11	2.31	.375	.437	1.38	.25	D (See Below Chart)								
Spline Data Code	Number of Teeth	Pitch	Major Diameter	Form Diameter	Minor Diameter	Minor Diameter								
D	14	12/24	1.248/1.247	1.07	1.063/1.050	Major dia. fit								

4520V INSTALLATION DIMENSION

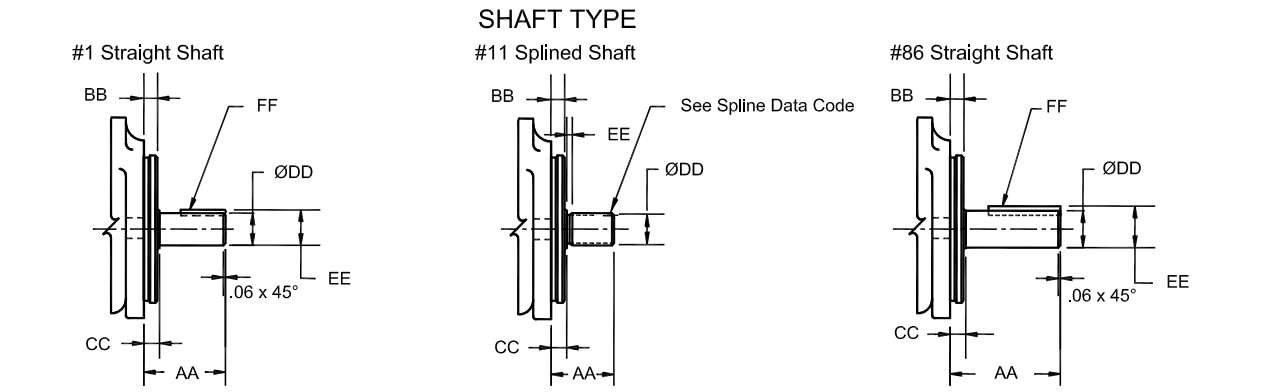
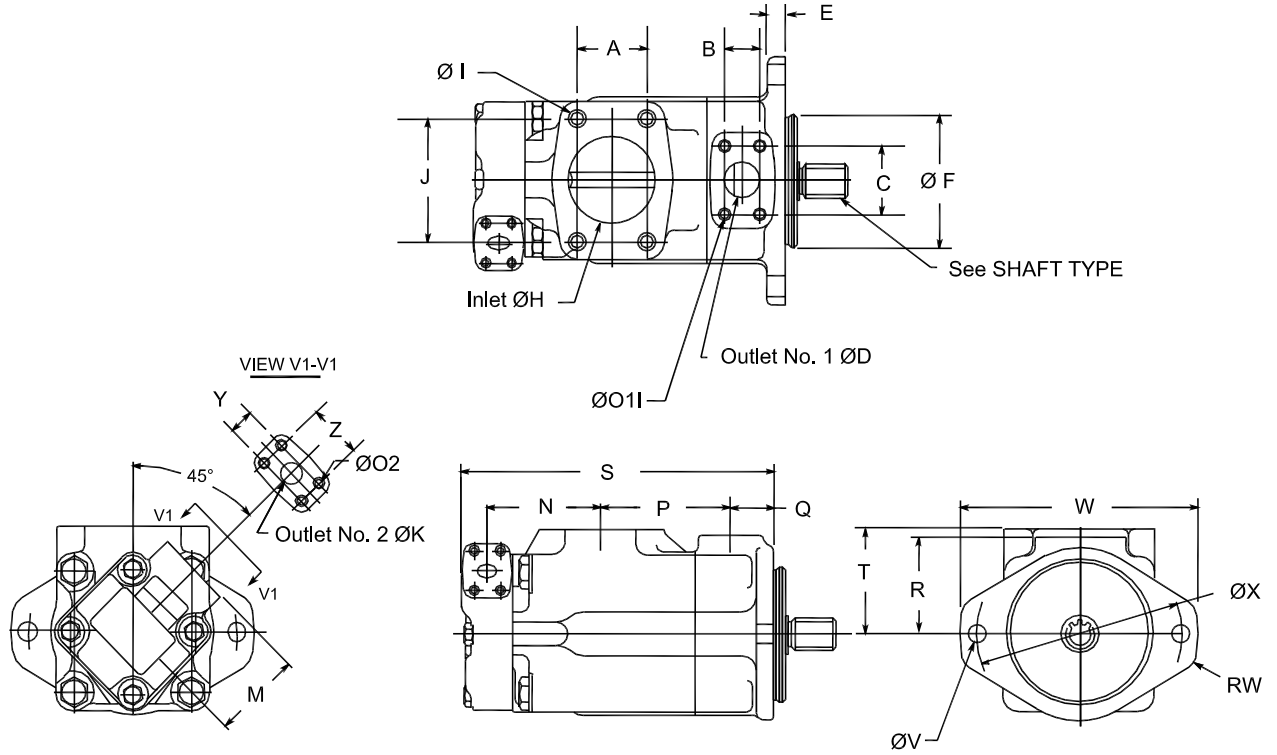

	A	B	C	øD	E	øF	øH	J	øK	M	N	P	Q	R	
BODY	2.75	1.41	2.75	1.50	0.62	5.000/4.998	3.50	4.75	0.75	3.00	4.72	4.70	1.69	3.69	
	S	T	øV x 2	RW	W	øX	Y	Z							
	12.08	4.03	0.69	0.63	8.38	7.13	0.88	1.88							
PORT CONN.	øO1 x 4 Holes			øO2 x 4 Holes			øI x 4 Holes			Outlet No 1 Flange		Outlet No 2 Flange		Inlet Flange	
	12"-13UNC-2B x 0.94			3/8"-16UNC-2B x 0.75			5/8"-11UNC-2B x 1.25			F1-12-		F1-6-		F1-28-	
SHAFT TYPE	Shaft Type	AA	BB	CC	øDD	EE	FF Key Width x Length								
	1	2.44	.500	.560	1.250/1.248	1.390/1.380	.312x1.12								
	86	3.44	.500	.560	1.499/1.498	1.669/1.659	.375x2.00								
	Shaft Type	AA	BB	CC	øDD	EE	Spline Data Code								
11	2.44	.500	.565	1.56	.38	D (See Below Chart)									
Spline Data Code	Number of Teeth	Pitch	Major Diameter	Form Diameter	Minor Diameter	Minor Diameter									
D	14	12/24	1.248/1.247	1.07	1.063/1.050	Major dia. fit									

4525V INSTALLATION DIMENSION

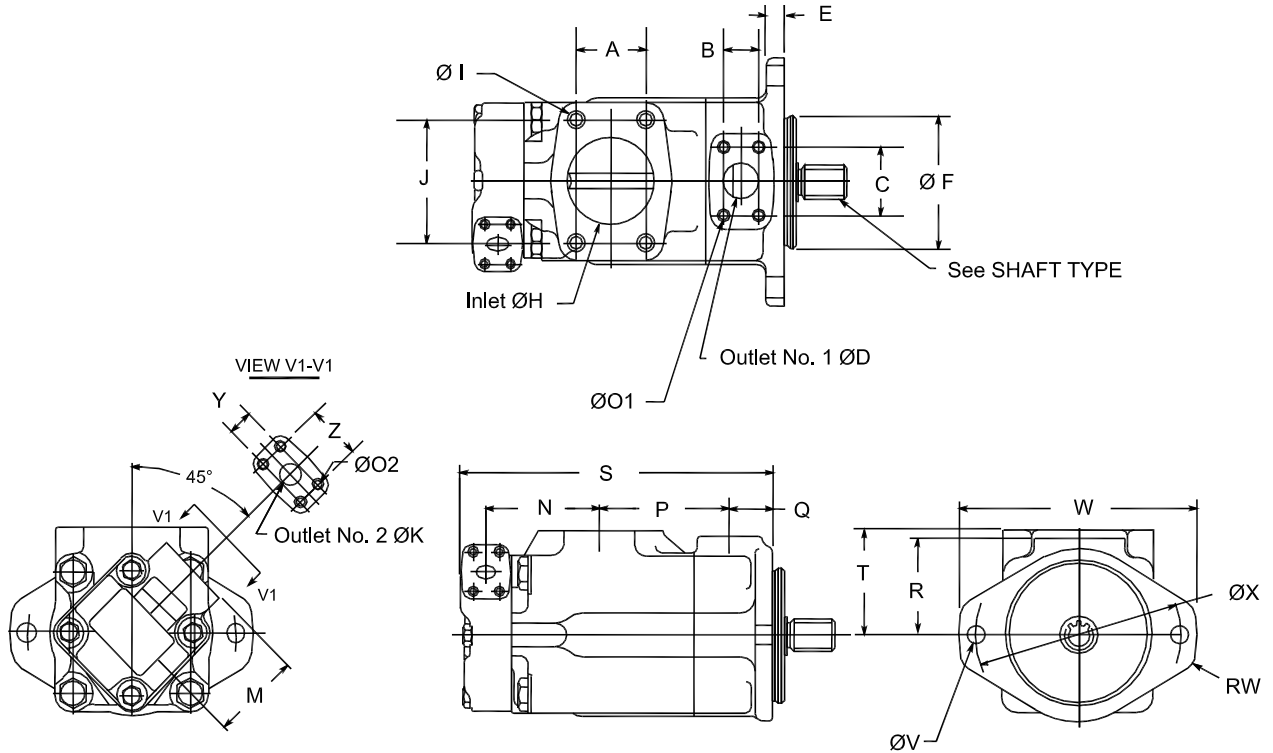

#1 Straight Shaft

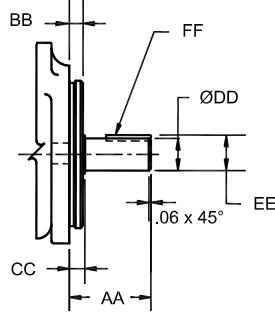

SHAFT TYPE

#11 Splined Shaft

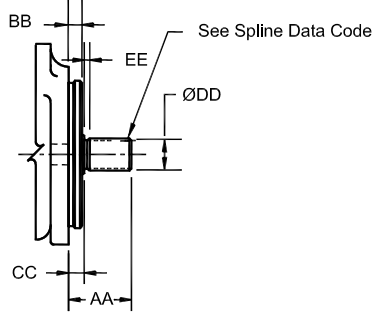

#86 Straight Shaft

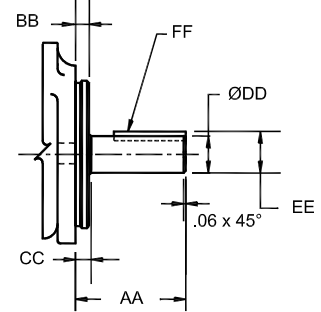

BODY	A	B	C	øD	E	øF	øH	J	øK	M	N	P	Q	R
		2.75	1.41	2.75	1.50	0.62	5.000/4.998	3.50	4.75	1.00	2.94	5.35	4.70	1.69
PORT CONN.	S	T	øV x 2	RW	W	øX	Y	Z						
	13.0	4.03	0.69	0.63	8.38	7.13	1.03	2.06						
SHAFT TYPE	øO1 x 4 Holes		øO2 x 4 Holes		øI x 4 Holes		Outlet No 1 Flange		Outlet No 2 Flange		Inlet Flange			
	12"-13UNC-2B x 0.94		3/8"-16UNC-2B x 0.66		5/8"-11UNC-2B x 1.25		F1-12-		F1-8-		F1-28-			
	Shaft Type	AA	BB	CC	øDD	EE	FF Key Width x Length							
	1	2.44	.500	.560	1.250/1.248	1.390/1.380	.312x1.12							
	86	3.44	.500	.560	1.499/1.498	1.669/1.659	.375x2.00							
Shaft Type	AA	BB	CC	øDD	EE	Spline Data Code								
11	2.44	.500	.565	1.56	.38	D (See Below Chart)								
Spline Data Code	Number of Teeth	Pitch	Major Diameter	Form Diameter	Minor Diameter	Minor Diameter								
D	14	12/24	1.248/1.247	1.07	1.063/1.050	Major dia. fit								

4535V INSTALLATION DIMENSION

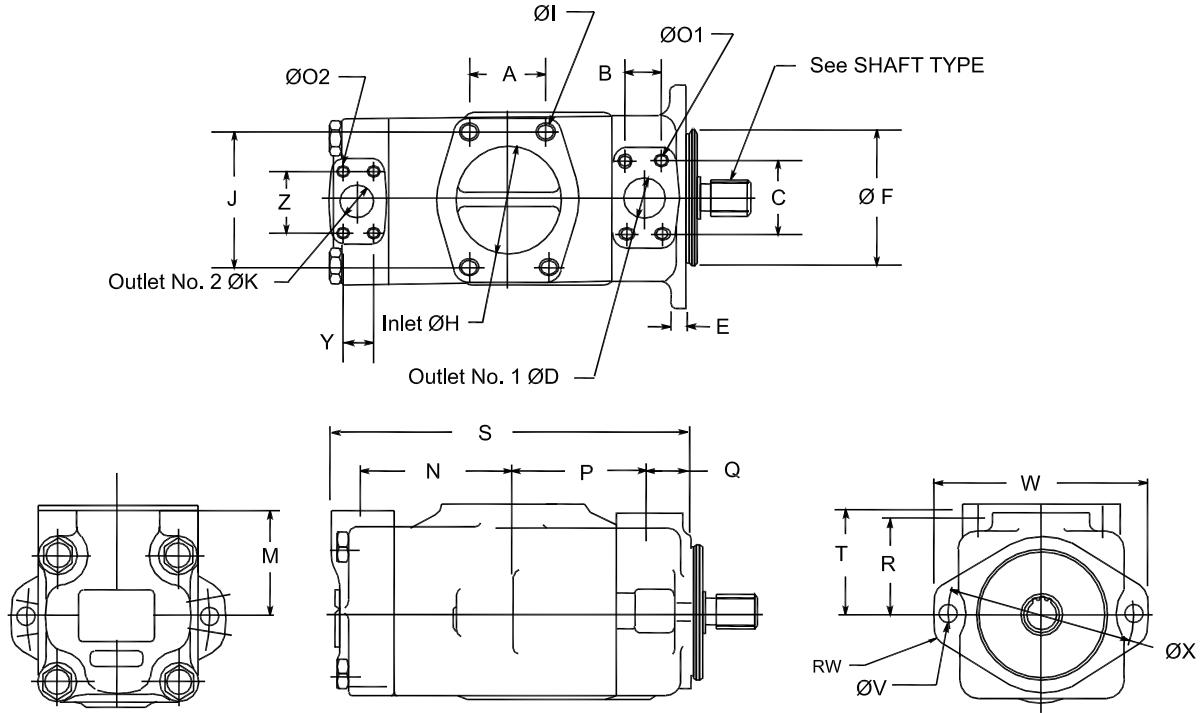

SHAFT TYPE

#1 Straight Shaft

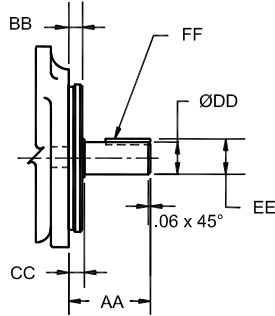

#11 Splined Shaft

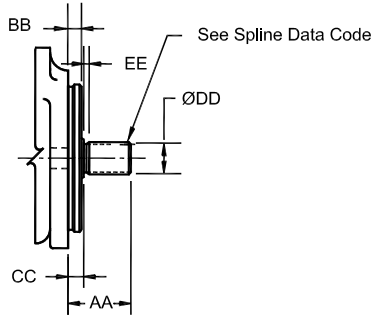

#86 Straight Shaft

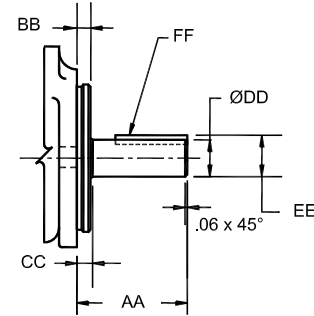

	A	B	C	øD	E	øF	øH	J	øK	M	N	P	Q	R	
BODY	3.06	1.41	2.75	1.50	0.62	5.000/4.998	4.00	5.13	1.25	4.00	5.84	5.25	1.69	3.69	
	S	T	øV x 2	RW	W	øX	Y	Z							
	13.9	4.03	0.69	0.63	8.38	7.13	1.19	2.31							
PORT CONN.	ØO1 x 4 Holes			ØO2 x 4 Holes			Ø I x 4 Holes			Outlet No 1 Flange		Outlet No 2 Flange		Inlet Flange	
	1/2"-13UNC-2B x 0.94			7/16"-14UNC-2B x 0.88			5/8"-11UNC-2B x 1.25			F1-12-		F1-10-		F1-32-	
SHAFT TYPE	Shaft Type	AA	BB	CC	øDD	EE	FF Key Width x Length								
	1	2.44	.500	.560	1.250/1.248	1.390/1.380	.312x1.12								
	86	3.44	.500	.560	1.499/1.498	1.669/1.659	.375x2.00								
	Shaft Type	AA	BB	CC	øDD	EE	Spline Data Code								
11	2.44	.500	.565	1.56	.38	D (See Below Chart)									
Spline Data Code	Number of Teeth	Pitch	Major Diameter	Form Diameter	Minor Diameter	Minor Diameter									
D	14	12/24	1.248/1.247	1.07	1.063/1.050	Major dia. fit									

(F3) - 25VQ 17 A - 1 C 22 L

 1 2 3 4 5 6 7 8

1 Special Seals

 Omit - (Standard)
 F3 - Viton Seals

2 Series No

 20VQ 25VQ 35VQ
 45VQ

3 Pump (GPM)

 (@1200 RPM, 100 PSI)

20VQ 25VQ 35VQ

2	10	25
5	12	30
8	14	32
9	17	35
11	19	38
12	21	
14		

 45VQ

 42
 45
 50
 60
 75

4 Port Connection

 A - SAE 4-Bolt Flange (Standard)

5 Shaft Type

 1 - Straight Keyed (Standard)
 151 - Splined
 (20VQ Only)
 11 - Splined
 86 - Straight Keyed
 (Heavy Duty Except 20VQ)

6 Outlet Port Position

 (View From Cover End of Pump)
 A - Opposite Inlet
 B - 90° CCW From Inlet
 C - Inline With Inlet (Standard)
 D - 90° CW From Inlet

7 Design Number

 22 - (Standard)
 10 - Design Change

8 Rotation

 (View From Shaft End of Pump)
 Omit - Right Hand Rotation
 (Standard)
 L - Left Hand Rotation



ITEM	20VQ			25VQ		35VQ		45VQ	
	2,5,8,9,11	12	14	10,12,14	17,19,21	25,30	32,35,38	42,45,50,60	75
MAX SPEED (RPM)	2700			2700	2500	2500	2400	2200	
MAX PRESSURE (PSI)	3000	2300	2000	3000		3000		2500	2000

(F3) - 2520VQ 17 A 11 - 1 C C 22 L

 1 2 3 4 5 6 7 8 9 10

1 Special Seals

Omit - (Standard)
 F3 - Viton Seals

2 Series No

2520VQ	3520VQ	3525VQ
4520VQ	4525VQ	4535VQ

3 Shaft End Pump (GPM)

(@1200 RPM, 100 PSI)
 25**VQ 35**VQ 45**VQ

10	25	42
12	30	45
14	32	50
17	35	60
19	38	75
21		

4 Port Connection

A - SAE 4-Bolt Flange (Standard)

5 Cover End Pump (GPM)

(@1200 RPM, 100 PSI)
 **20VQ **25VQ **35VQ

2	10	25
5	12	30
8	14	32
9	17	35
11	19	38
12	21	
14		

6 Shaft Type

1 - Straight Keyed (Standard)
 11 - Splined
 86 - Straight Keyed (Heavy Duty)

7 Outlet No 1 Port Position

(View From Cover End of Pump)
 A - Opposite Inlet
 B - 90° CCW From Inlet
 C - Inline With Inlet (Standard)
 D - 90° CW From Inlet

8 Outlet No 2 Port Position

(View From Cover End of Pump)
 All Series Except 4535VQ
 A - 135° CCW From Inlet
 B - 45° CCW From Inlet
 C - 45° CW From Inlet (Standard)
 D - 135° CW From Inlet

 Series 4535VQ
 A - Opposite Inlet
 B - 90° CCW From Inlet
 C - Inline with Inlet (Standard)
 D - 90° CW From Inlet

9 Design Number

22 - (Standard)
 10 - Design Change

10 Rotation

(View From Shaft End of Pump)
 Omit - Right Hand Rotation (Standard)
 L - Left Hand Rotation

NOTE: See Respective Pump Performance in VQ Pump Performance for Double Pump Performance.



ITEM	**20VQ (FOR 2520VQ)			**20VQ (FOR 3520VQ)			**20VQ (FOR 4520VQ)			25**VQ (FOR 2520VQ)	
	5,8,11	12	14	5,8,11	12	14	2,5,8,9,11	12	14	10,12,14	17,19,21
MAX SPEED (RPM)	2700			2500			2200			2700	2500
MAX PRESSURE (PSI)	3000	2300	2000	3000	2300	2000	3000	2300	2000	3000	

ITEM	**25VQ (FOR 3525VQ)	**25VQ (FOR 4525VQ)	35**VQ		**35VQ	45**VQ	
	10,12,14,17,19,21	10,12,14,17,19,21	25,30	32,35,38	25,30,32,35,38	42,45,50,60	75
MAX SPEED (RPM)	2500	2200	2500	2400	2200	2200	
MAX PRESSURE (PSI)	3000	3000	3000		3000	2500	2000

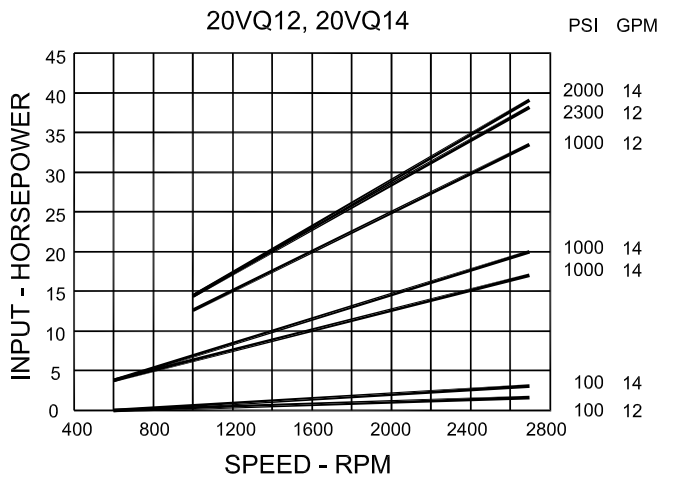
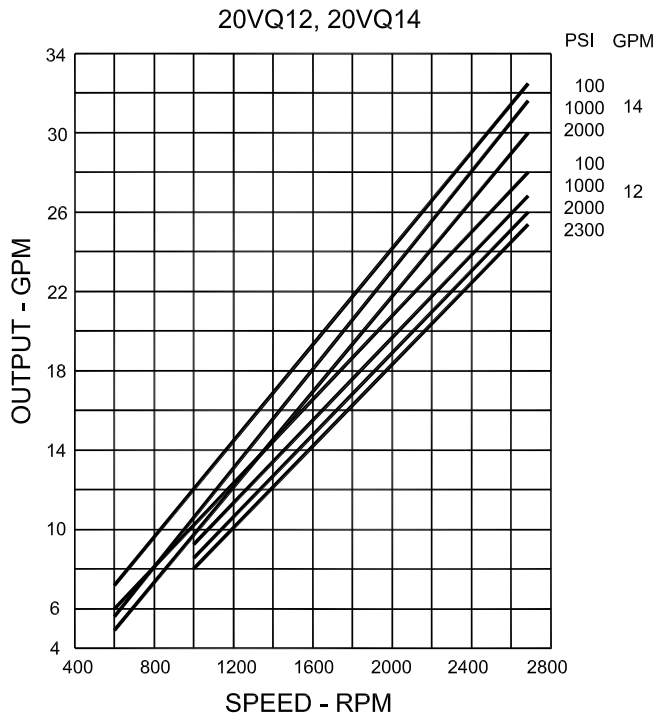
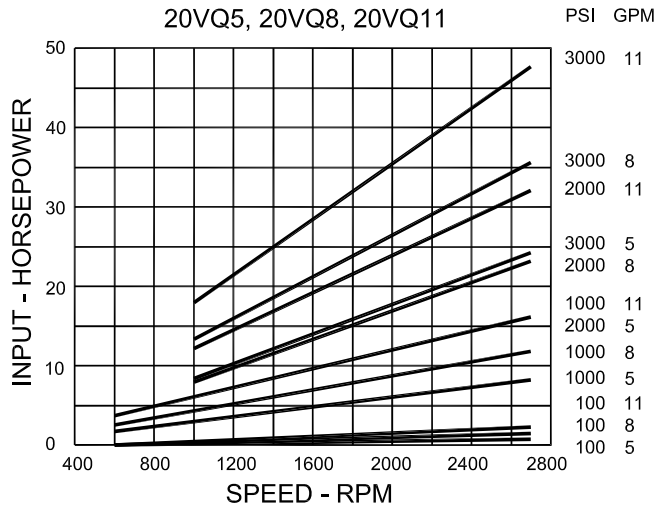
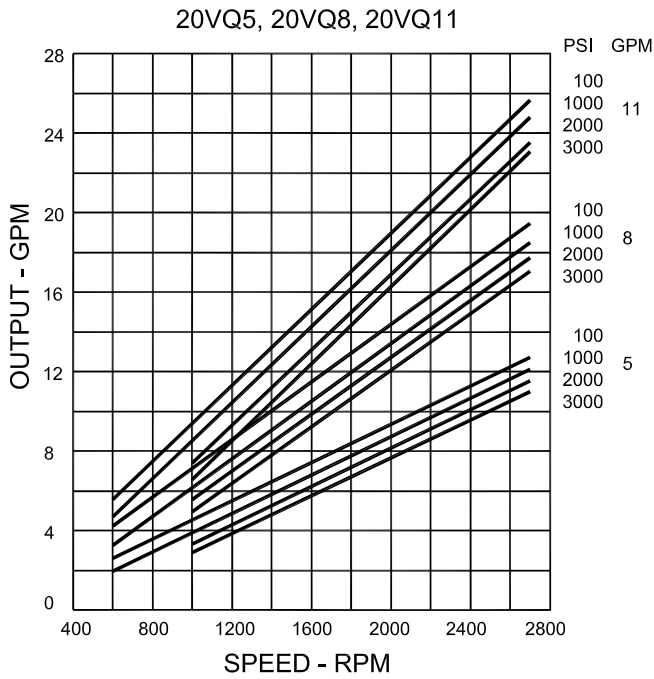

Data Based on SAE 10W Fluid @ 180°F and Pump Inlet @ 0 PSIG (14.7 PSIA)

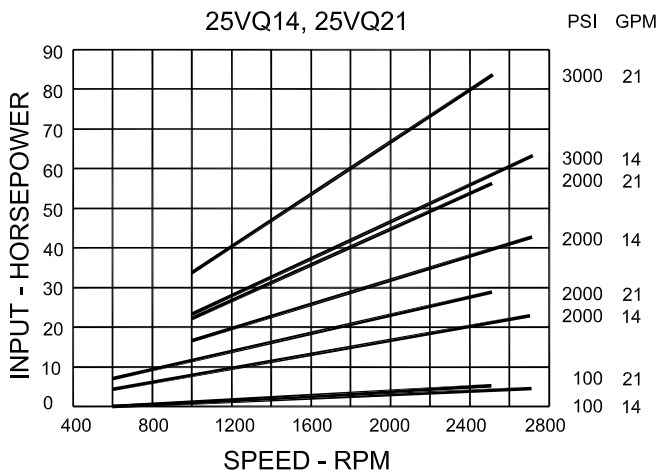
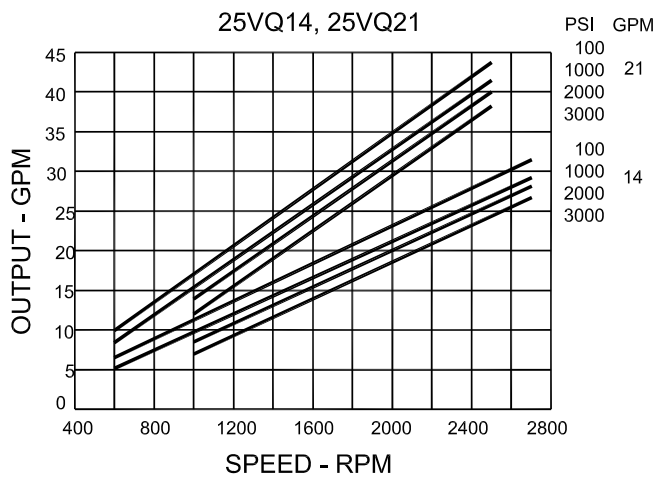
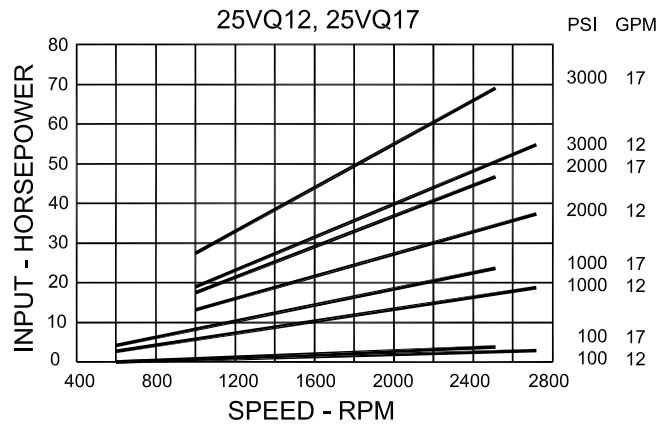
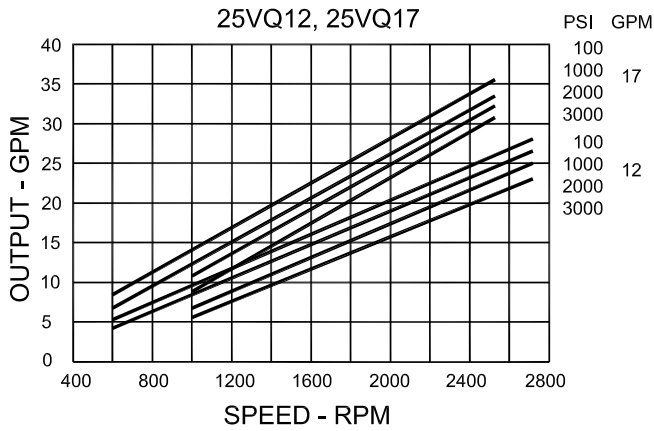

Data Based on SAE 10W Fluid @ 180°F and Pump Inlet @ 0 PSIG (14.7 PSIA)

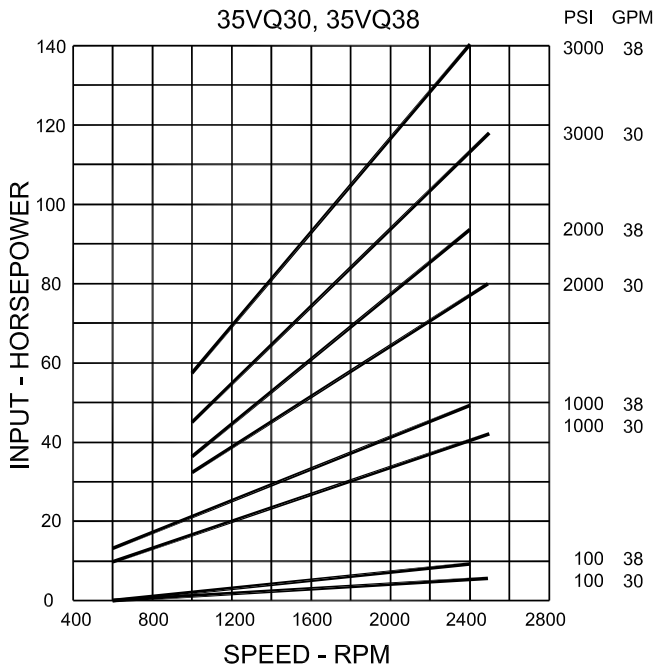
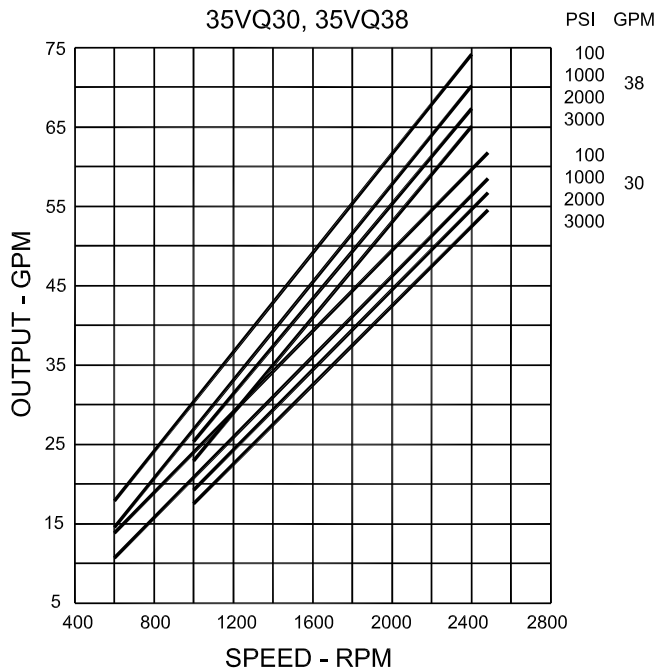
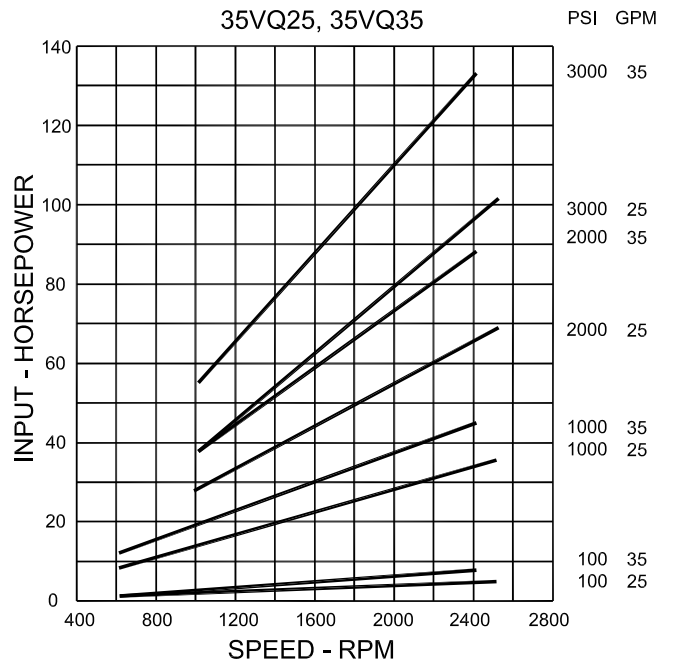
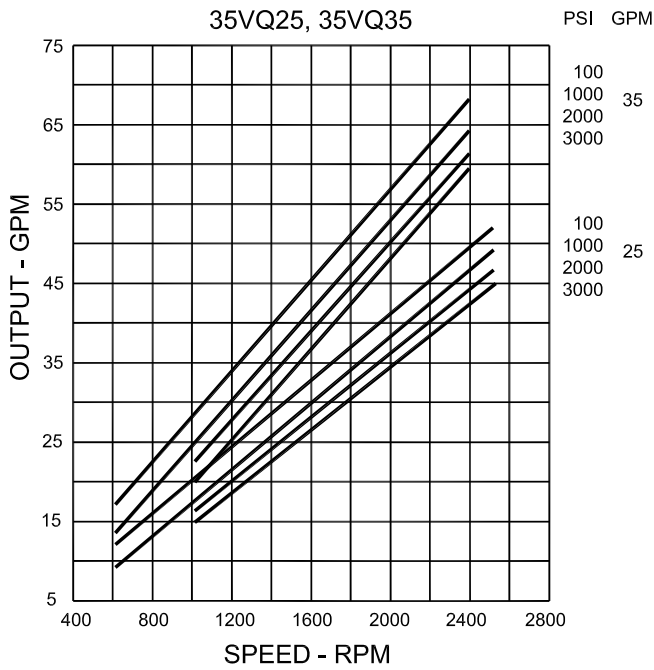

Data Based on SAE 10W Fluid @ 180°F and Pump Inlet @ 0 PSIG (14.7 PSIA)

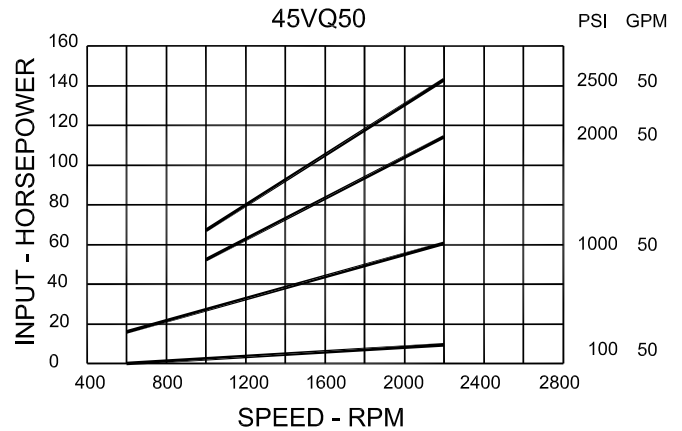
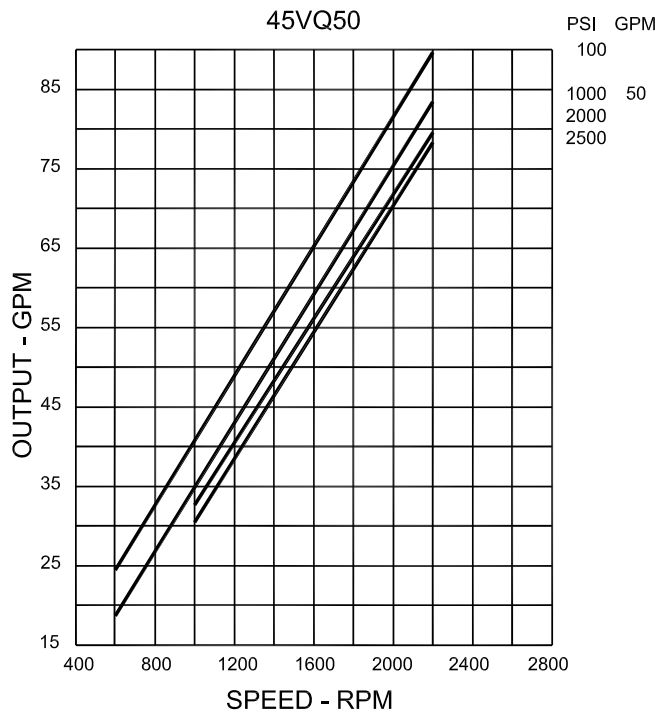
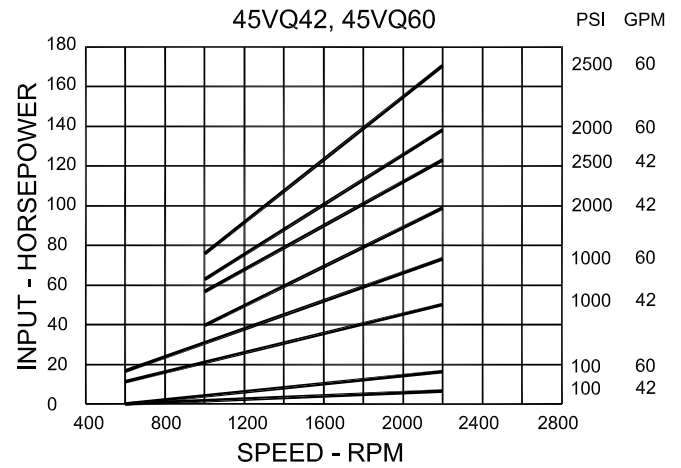
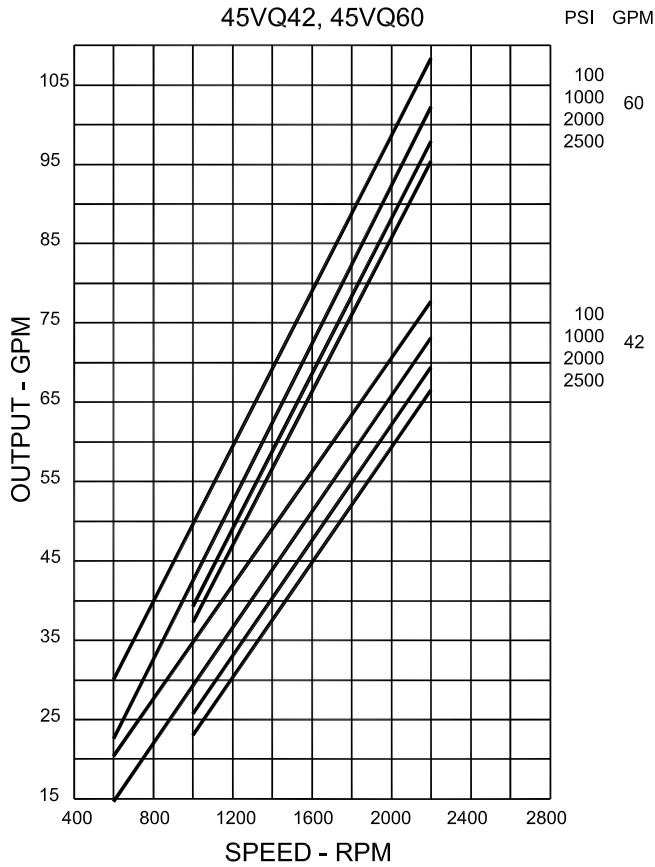

Data Based on SAE 10W Fluid @ 180°F and Pump Inlet @ 0 PSIG (14.7 PSIA)

20VQ INSTALLATION DIMENSION

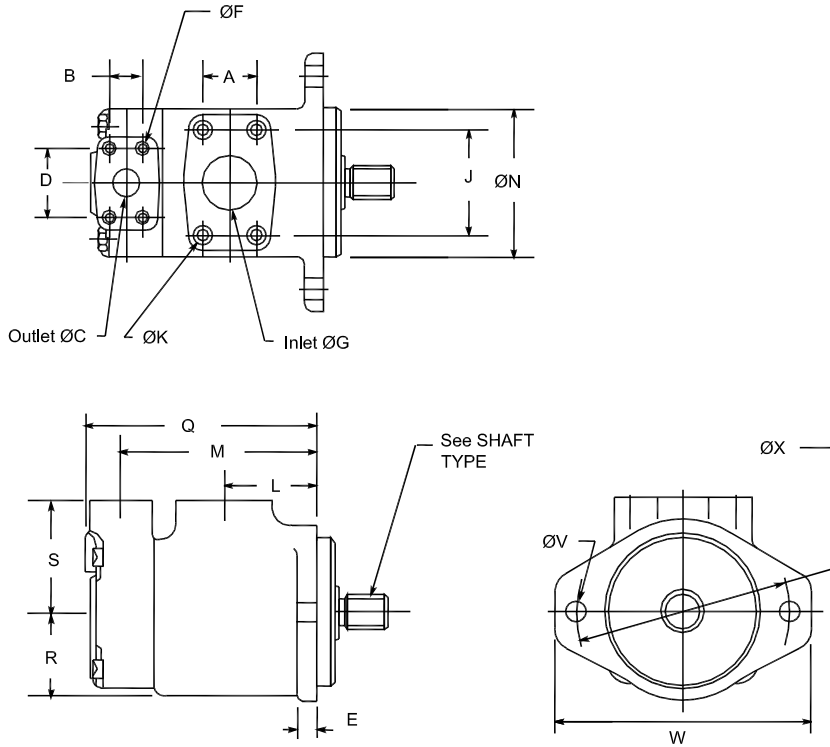

SHAFT TYPE

#1 Straight Shaft

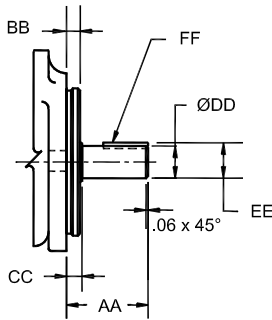

#151 Splined Shaft

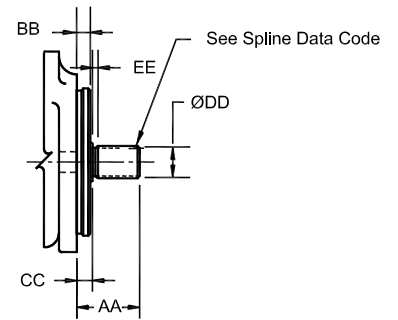

		A	B	ØC	D	E	ØG	J	L	M	ØN	
BODY		1.41	0.875	0.75	1.87	0.50	1.50	2.75	2.5	5.22	4.000/3.998	
		Q	R	S	ØV x 2	W	ØX					
		6.12	2.2	3.00	0.56	6.875	5.75					
PORT CONN.		ØF x 4 Holes			ØK x 4 Holes			Outlet Flange		Inlet Flange		
		3/8"-16UNC-2B x 0.75			1/2"-13UNC-2B x 0.83			F1-6-		F1-12-		
SHAFT TYPE		Shaft Type	AA	BB	CC	ØDD	EE	FF Key Width x Length				
		1	2.32	.375	.476	.875/.874	.966/.961	.187x1.25				
		Shaft Type	AA	BB	CC	ØDD	EE	Spline Data Code				
		151	1.62	.375	.437	1.09	.156	A (See Below Chart)				
	Spline Data Code	Number of Teeth	Pitch	Major Diameter	Form Diameter	Minor Diameter	Minor Diameter					
	A	13	16/32	.873/.872	.749	.734/.723	Major dia. fit					

25VQ INSTALLATION DIMENSION

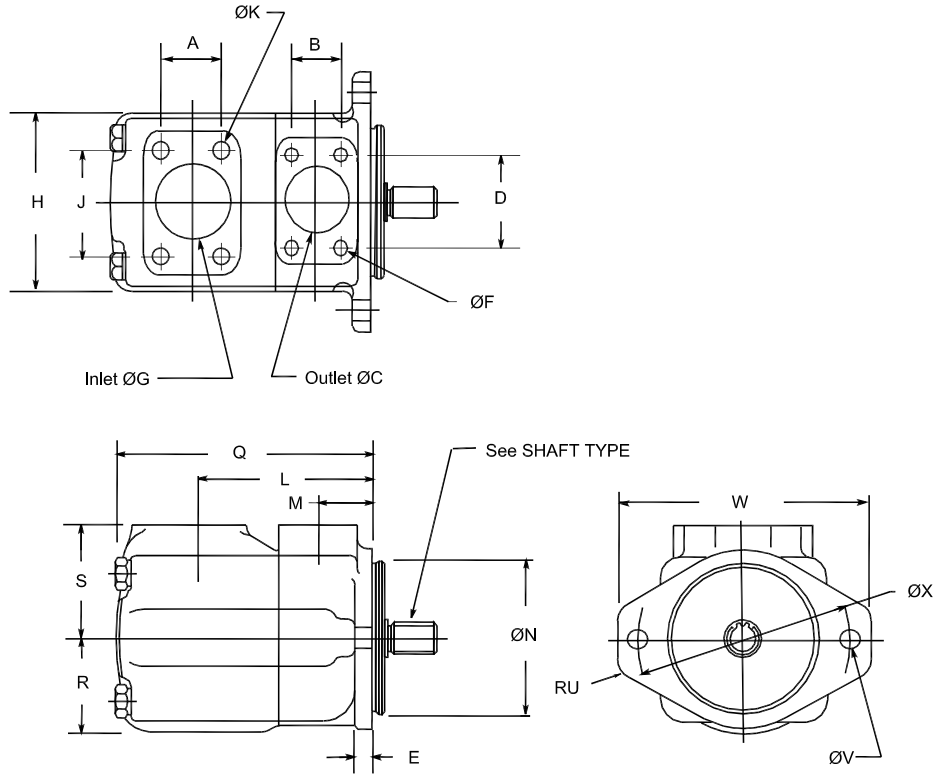

SHAFT TYPE

#1 Straight Shaft

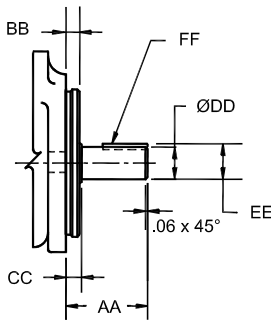

#11 Splined Shaft

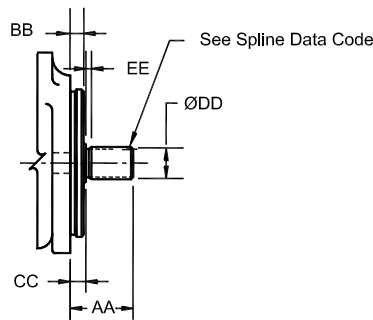

#86 Straight Shaft

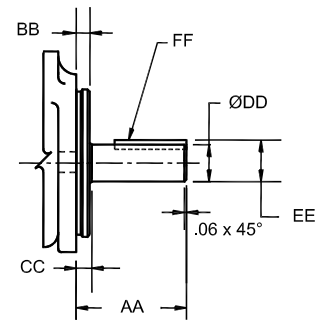

BODY	A	B	ØC	D	E	ØG	H	J	L	M	ØN
		1.41	1.03	1.00	2.06	0.50	1.50	4.62	2.75	4.76	1.50
PORT CONN.	Q		R	S	RU		ØV x 2		W	ØX	
	6.38		2.50	3.00	0.55		0.56		6.88	5.75	
SHAFT TYPE	ØF x 4 Holes		ØK x 4 Holes		Outlet Flange		Inlet Flange				
	3/8"-16UNC-2B x 0.75		1/2"-13UNC-2B x 0.94		FL1-8-		FL1-12-				
SHAFT TYPE	Shaft Type	AA	BB	CC	ØDD		EE	FF Key Width x Length			
	1	2.32	.375	.437	.875/.874		.966/.961	.187x1.25			
	86	3.06	.375	.437	.999/.998		1.11/1.10	.250x2.00			
	Shaft Type	AA	BB	CC	ØDD	EE	Spline Data Code				
11	1.75	.375	.437	1.09	.156	A (See Below Chart)					
Spline Data Code	Number of Teeth	Pitch	Major Diameter	Form Diameter	Minor Diameter	Minor Diameter					
A	13	16/32	.873/.872	.749	.734/.723	Major dia. fit					

35VQ INSTALLATION DIMENSION

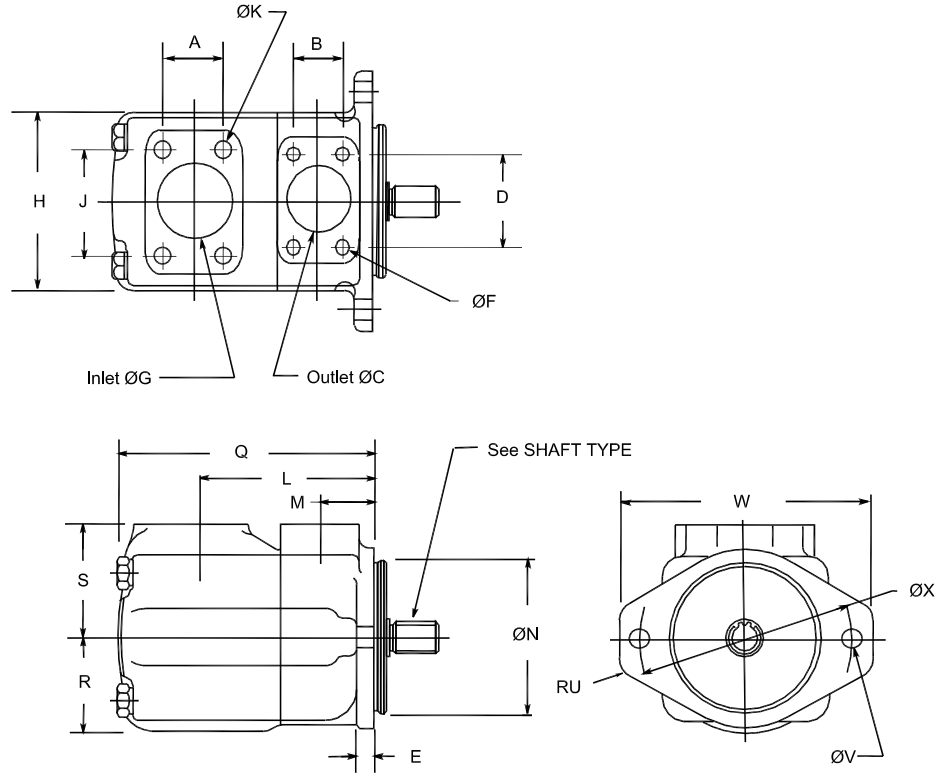

SHAFT TYPE

#1 Straight Shaft

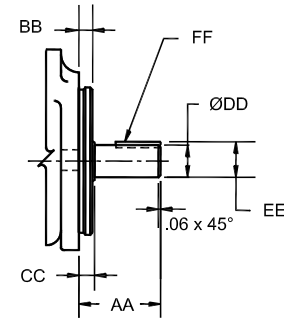

#11 Splined Shaft

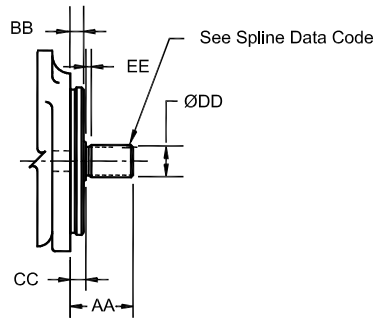

#86 Straight Shaft

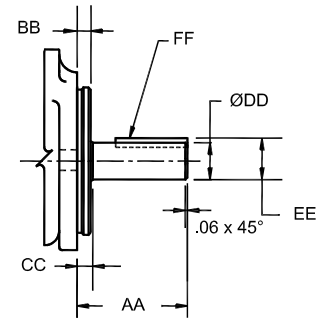

BODY	A	B	ØC	D	E	ØG	H	J	L	M	ØN
	1.69	1.19	1.25	2.31	0.63	2.00	5.50	3.06	4.94	1.50	5.000/4.998
PORT CONN.	Q		R	S	RU		ØV x 2	W	ØX		
	7.28	2.75	3.25	0.63	0.69	8.38	7.13				
SHAFT TYPE	ØF x 4 Holes		ØK x 4 Holes		Outlet Flange		Inlet Flange				
	7/16"-14UNC-2B x 0.88		1/2 "-13UNC-2B x 0.88		F1-10-		F1-16-				
	Shaft Type	AA	BB	CC	ØDD	EE	FF Key Width x Length				
	1	2.88	.375	.437	1.250/1.248	1.392/1.382	.313x1.50				
86	3.88	.375	.437	1.374/1.373	1.518/1.508	.312x2.13					
Shaft Type	AA	BB	CC	ØDD	EE	Spline Data Code					
11	2.31	.375	.437	1.38	.25	D (See Below Chart)					
Spline Data Code	Number of Teeth	Pitch	Major Diameter	Form Diameter	Minor Diameter	Minor Diameter					
D	14	12/24	1.248/1.247	1.07	1.063/1.050	Major dia. fit					

45VQ INSTALLATION DIMENSION

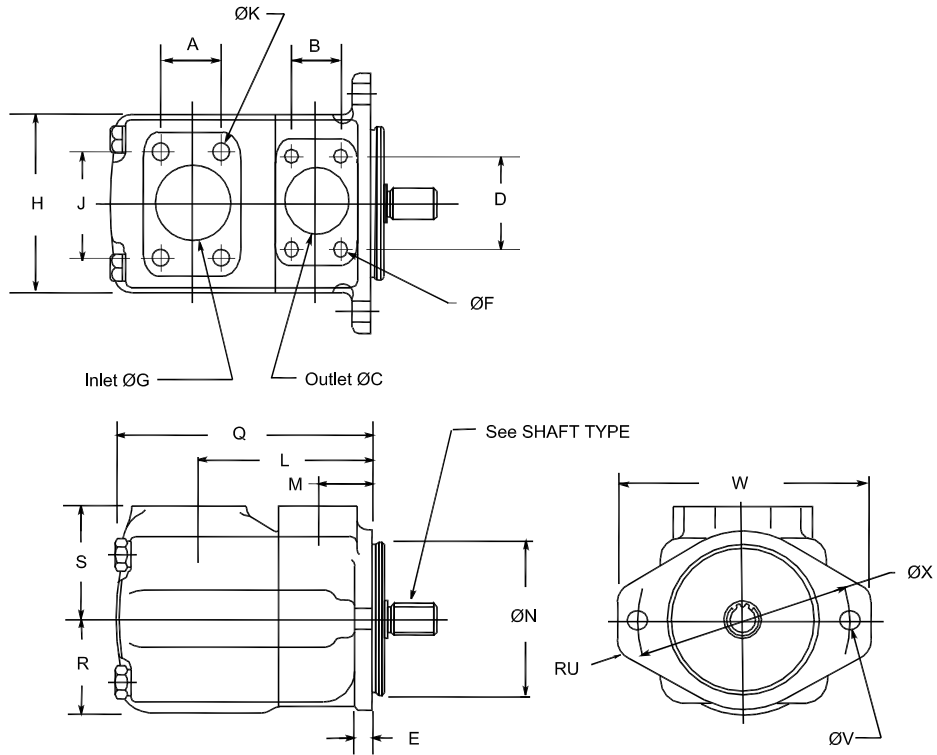

SHAFT TYPE

#1 Straight Shaft

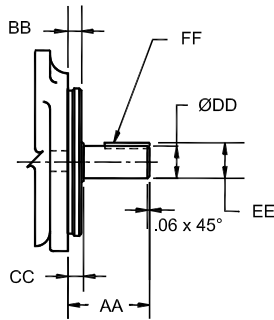

#11 Splined Shaft

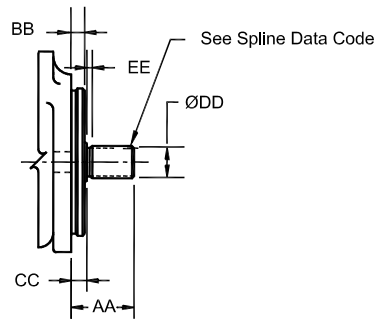

#86 Straight Shaft

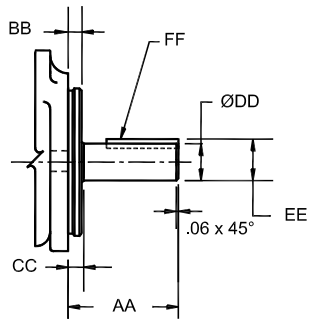

	A	B	ØC	D	E	ØG	H	J	L	M	ØN	
BODY	2.43	1.41	1.50	2.75	0.63	3.00	6.25	4.19	6.03	1.69	5.000/4.998	
	Q	R	S	RU	ØV x 2	W	ØX					
	8.50	3.25	3.69	0.63	0.69	8.38	7.13					
PORT CONN.	ØF x 4 Holes			ØK x 4 Holes			Outlet Flange		Inlet Flange			
	1/2"-13UNC-2B x 0.94			5/8 "-11UNC-2B x 1.18			F1-12-		F1-24-			
SHAFT TYPE	Shaft Type	AA	BB	CC	ØDD	EE	FF Key Width x Length					
	1	2.44	.500	.560	1.250/1.248	1.390/1.380	.312x1.12					
	86	3.44	.500	.560	1.499/1.498	1.669/1.659	.375x2.00					
	Shaft Type	AA	BB	CC	ØDD	EE	Spline Data Code					
11	2.44	.500	.565	1.56	.38	D (See Below Chart)						
	Spline Data Code	Number of Teeth	Pitch	Major Diameter	Form Diameter	Minor Diameter	Minor Diameter					
	D	14	12/24	1.248/1.247	1.07	1.063/1.050	Major dia. fit					

2520VQ INSTALLATION DIMENSION

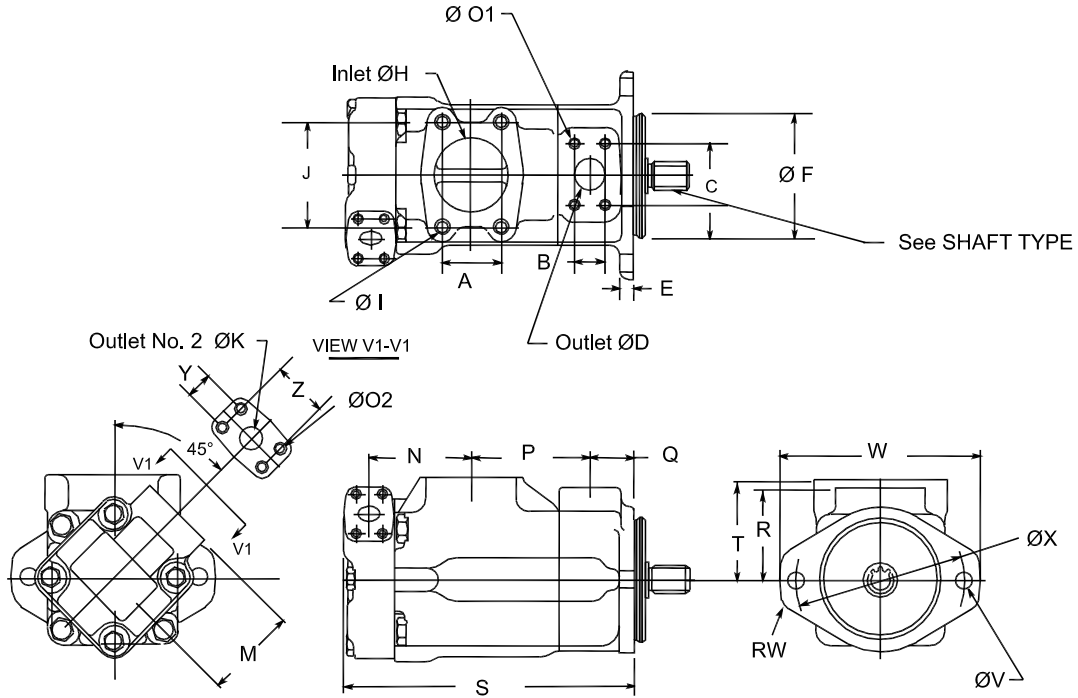

SHAFT TYPE

#1 Straight Shaft

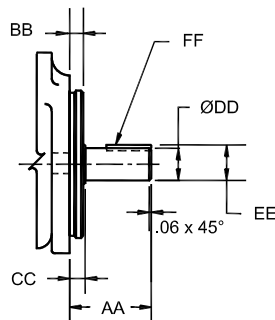

#11 Splined Shaft

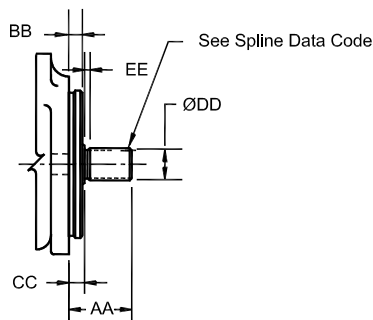

#86 Straight Shaft

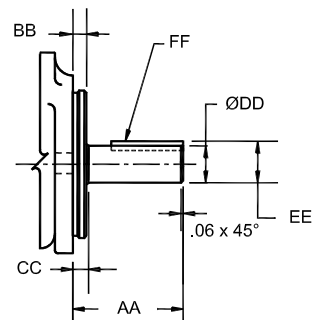

BODY	A	B	C	øD	E	øF	øH	J	øK	M	N	P	Q	R
		2.00	1.03	2.06	1.00	0.50	4.000/3.998	2.50	3.50	0.75	3.00	3.47	4.00	1.50
PORT CONN.	S	T	øV x 2	RW	W	øX	Y	Z						
	9.94	3.31	0.56	0.55	6.88	5.75	0.88	1.88						
SHAFT TYPE	øO1 x 4 Holes		øO2 x 4 Holes		øI x 4 Holes		Outlet No 1 Flange		Outlet No 2 Flange		Inlet Flange			
	3/8"-16UNC-2B x 0.75		3/8"-16UNC-2B x 0.75		1/2"-13UNC-2B x 0.94		F1-8-		F1-6-		F1-20-			
SHAFT TYPE	Shaft Type	AA	BB	CC	øDD	EE	FF Key Width x Length							
	1	2.32	.375	.437	.875/.874	.966/.961	.187x1.25							
	86	3.06	.375	.437	.999/.998	1.11/1.10	.250x2.00							
SHAFT TYPE	Shaft Type	AA	BB	CC	øDD	EE	Spline Data Code							
	11	1.75	.375	.437	1.09	.156	A (See Below Chart)							
	Spline Data Code	Number of Teeth	Pitch	Major Diameter	Form Diameter	Minor Diameter	Minor Diameter							
A	13	16/32	.873/.872	.749	.734/.723	Major dia. fit								

3520VQ INSTALLATION DIMENSION

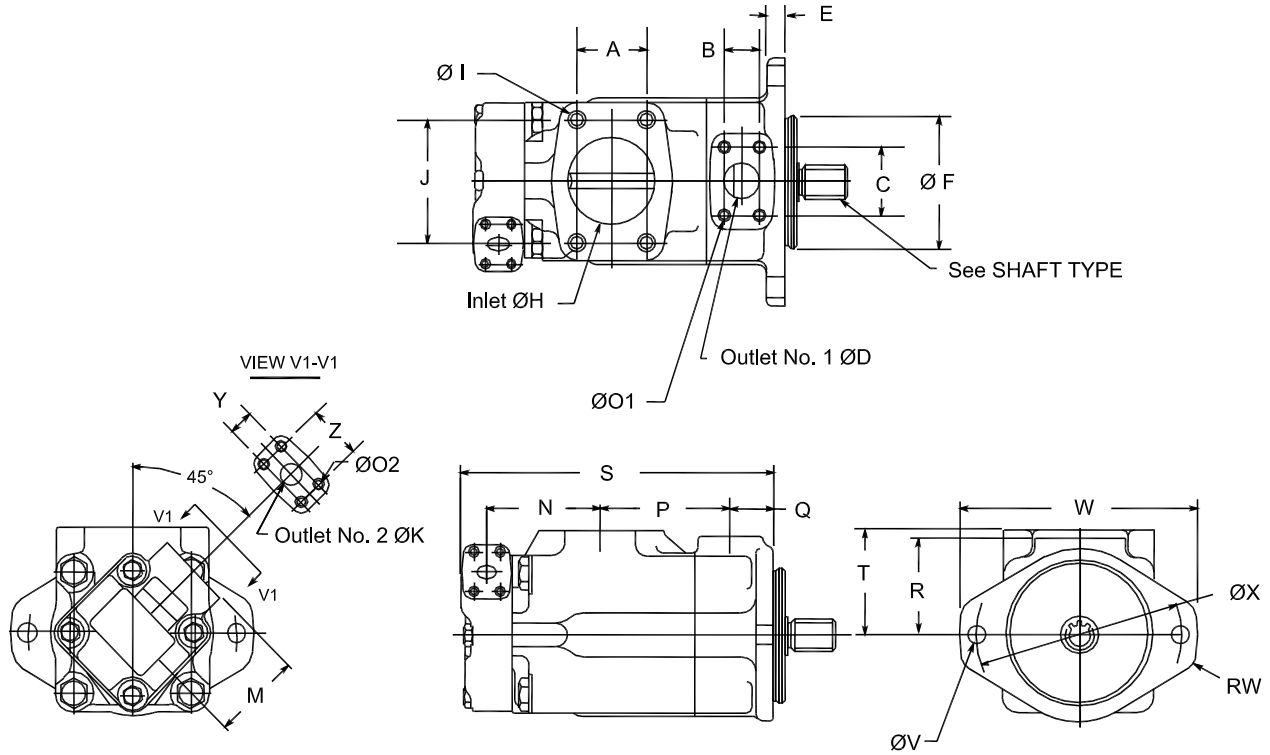

SHAFT TYPE

#1 Straight Shaft

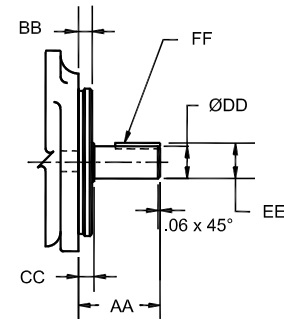

#11 Splined Shaft

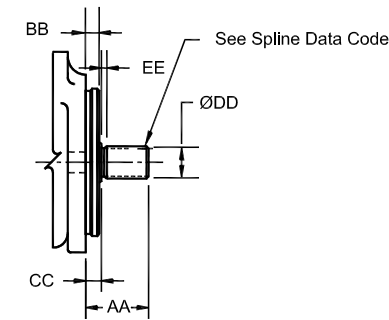

#86 Straight Shaft

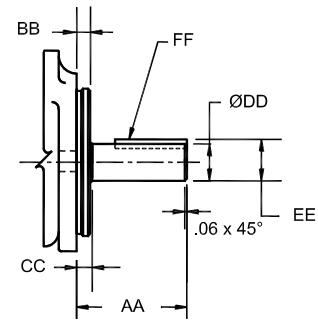

	A	B	C	ØD	E	ØF	ØH	J	ØK	M	N	P	Q	R	
BODY	2.44	1.19	2.31	1.25	0.62	5.000/4.998	3.00	4.19	0.75	3.00	3.92	4.50	1.50	3.25	
	S	T	ØV x 2	RW	W	ØX	Y	Z							
	10.9	3.50	0.69	0.63	8.38	7.13	0.88	1.88							
PORT CONN.	ØO1 x 4 Holes			ØO2 x 4 Holes			Ø I x 4 Holes			Outlet No 1 Flange		Outlet No 2 Flange		Inlet Flange	
	7/16"-14UNC-2B x 0.88			3/8"-16UNC-2B x 0.75			5/8"-11UNC-2B x 1.125			F1-10-		F1-6-		F1-24-	
SHAFT TYPE	Shaft Type	AA	BB	CC	ØDD	EE	FF Key Width x Length								
	1	2.88	.375	.437	1.250/1.248	1.392/1.382	.313x1.50								
	86	3.88	.375	.437	1.374/1.373	1.518/1.508	.312x2.13								
	Shaft Type	AA	BB	CC	ØDD	EE	Spline Data Code								
11	2.31	.375	.437	1.38	.25	D (See Below Chart)									
Spline Data Code	Number of Teeth	Pitch	Major Diameter	Form Diameter	Minor Diameter	Minor Diameter									
D	14	12/24	1.248/1.247	1.07	1.063/1.050	Major dia. fit									

3525VQ INSTALLATION DIMENSION

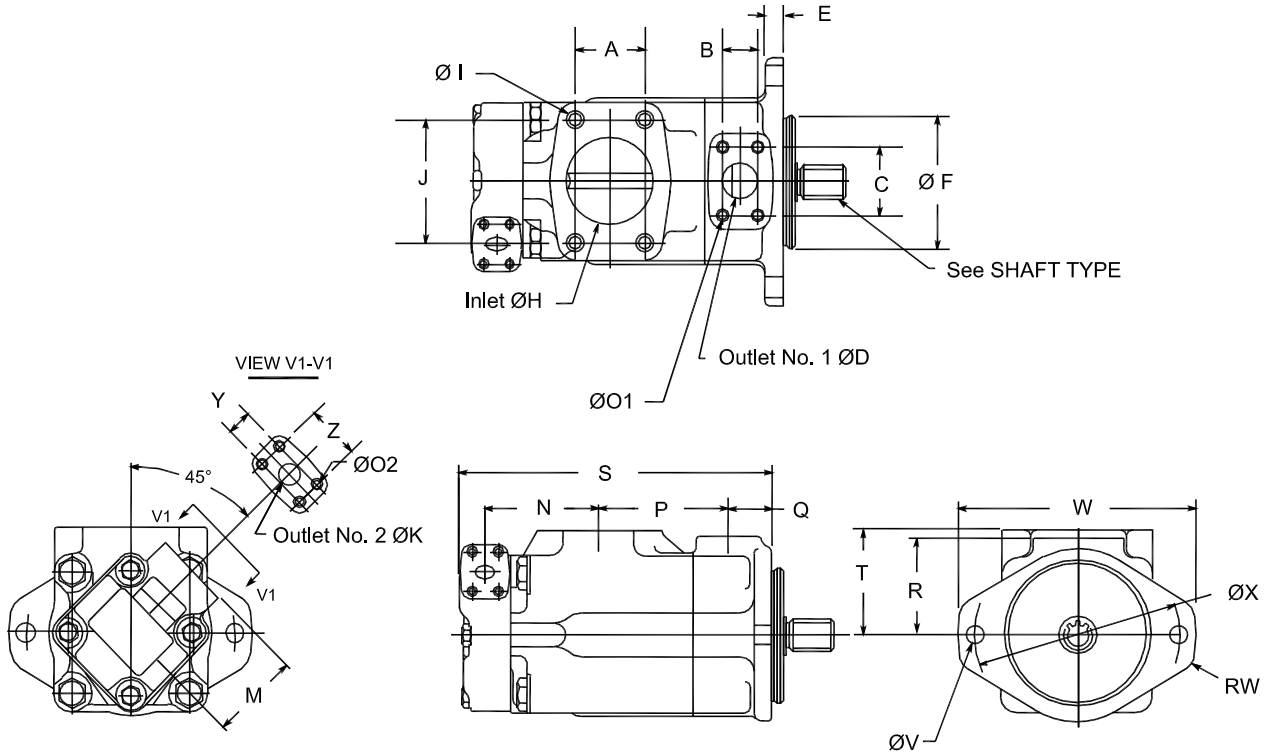

#1 Straight Shaft

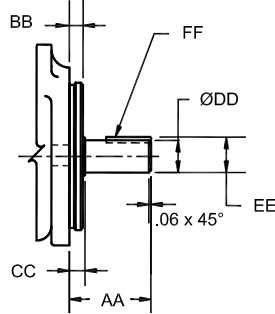

SHAFT TYPE

#11 Splined Shaft

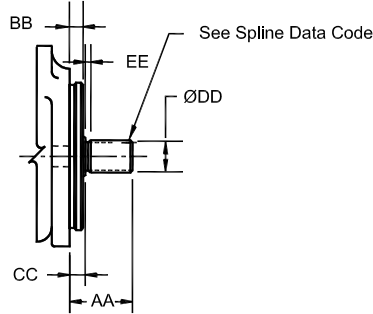

#86 Straight Shaft

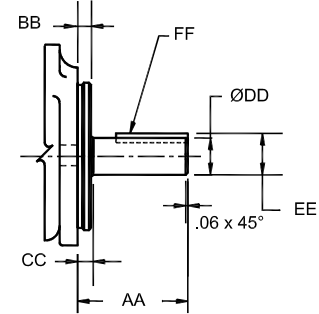

BODY	A	B	C	øD	E	øF	øH	J	øK	M	N	P	Q	R
		2.44	1.19	2.31	1.25	0.62	5.000/4.998	3.00	4.19	1.00	2.94	4.31	4.50	1.50
PORT CONN.	S	T	øV x 2	RW	W	øX	Y	Z						
	11.57	3.50	0.69	0.63	8.38	7.13	1.03	2.06						
SHAFT TYPE	øO1 x 4 Holes		øO2 x 4 Holes		øI x 4 Holes			Outlet No 1 Flange		Outlet No 2 Flange		Inlet Flange		
	7/16"-14UNC-2B x 0.88		3/8"-16UNC-2B x 0.66		5/8"-11UNC-2B x 1.125			F1-10-		F1-8-		F1-24-		
	Shaft Type	AA	BB	CC	øDD	EE	FF Key Width x Length							
	1	2.88	.375	.437	1.250/1.248	1.392/1.382	.313x1.50							
86	3.88	.375	.437	1.374/1.373	1.518/1.508	.312x2.13								
Shaft Type	AA	BB	CC	øDD	EE	Spline Data Code								
11	2.31	.375	.437	1.38	.25	D (See Below Chart)								
Spline Data Code	Number of Teeth	Pitch	Major Diameter	Form Diameter	Minor Diameter	Minor Diameter								
D	14	12/24	1.248/1.247	1.07	1.063/1.050	Major dia. fit								

4520VQ INSTALLATION DIMENSION

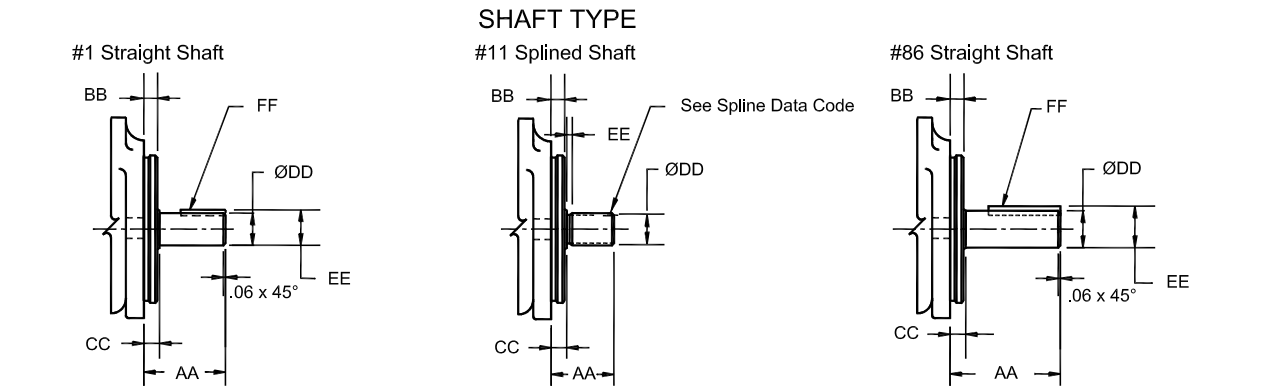
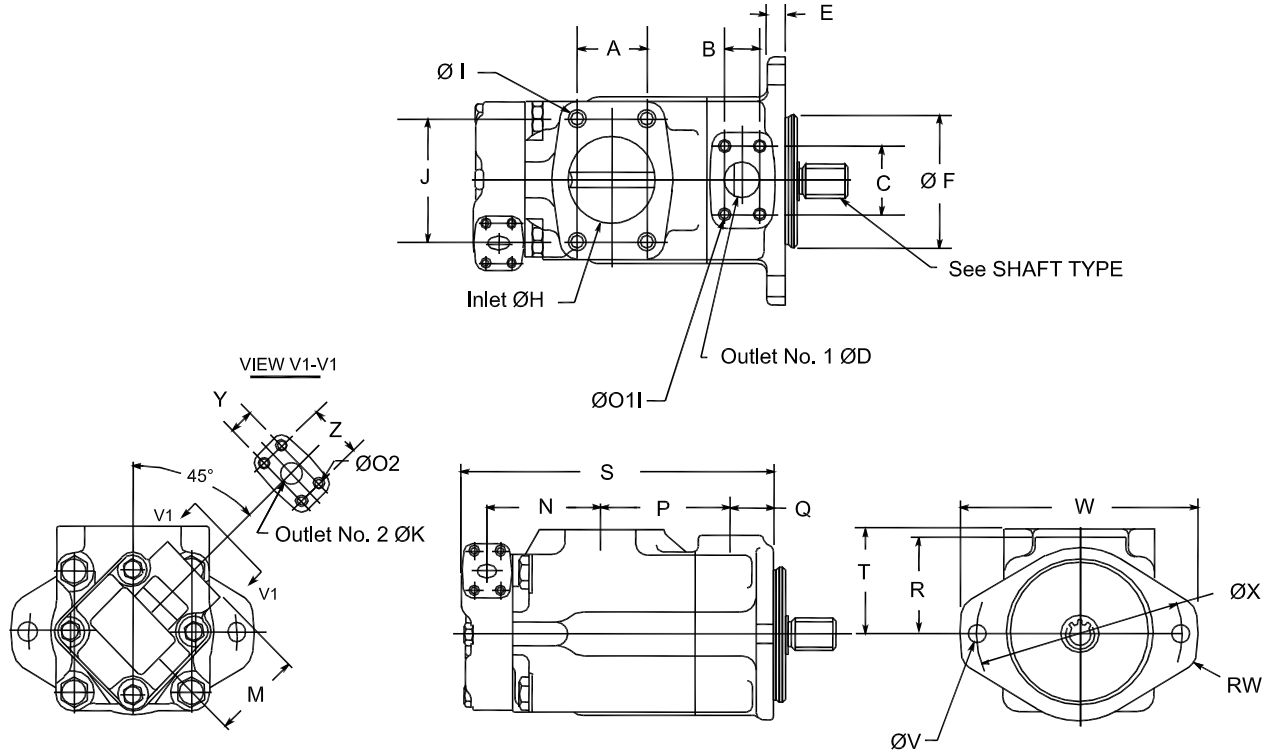

	A	B	C	ØD	E	ØF	ØH	J	ØK	M	N	P	Q	R	
BODY	2.75	1.41	2.75	1.50	0.62	5.000/4.998	3.50	4.75	0.75	3.00	4.72	4.70	1.69	3.69	
	S	T	ØV x 2	RW	W	ØX	Y	Z							
	12.08	4.03	0.69	0.63	8.38	7.13	0.88	1.88							
PORT CONN.	ØO1 x 4 Holes			ØO2 x 4 Holes			Ø I x 4 Holes			Outlet No 1 Flange		Outlet No 2 Flange		Inlet Flange	
	1/2"-13UNC-2B x 0.94			3/8"-16UNC-2B x 0.75			5/8"-11UNC-2B x 1.25			F1-12-		F1-6-		F1-28-	
SHAFT TYPE	Shaft Type	AA	BB	CC	ØDD	EE	FF Key Width x Length								
	1	2.44	.500	.560	1.250/1.248	1.390/1.380	.312x1.12								
	86	3.44	.500	.560	1.499/1.498	1.669/1.659	.375x2.00								
	Shaft Type	AA	BB	CC	ØDD	EE	Spline Data Code								
11	2.44	.500	.565	1.56	.38	D (See Below Chart)									
Spline Data Code	Number of Teeth	Pitch	Major Diameter	Form Diameter	Minor Diameter	Minor Diameter									
D	14	12/24	1.248/1.247	1.07	1.063/1.050	Major dia. fit									

4525VQ INSTALLATION DIMENSION

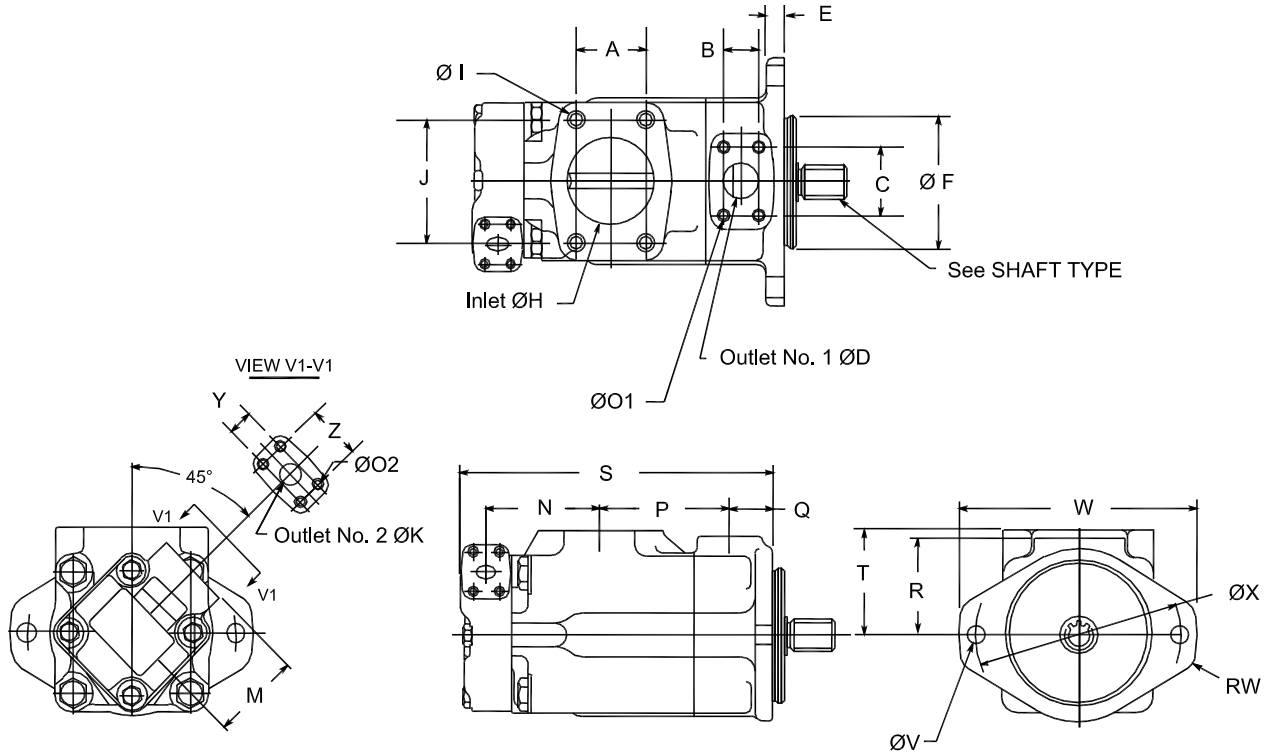

#1 Straight Shaft

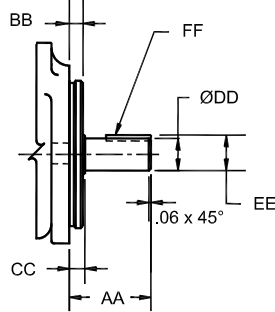

SHAFT TYPE

#11 Splined Shaft

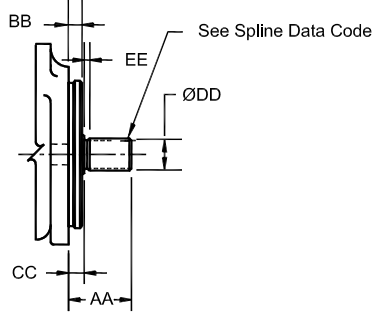

#86 Straight Shaft

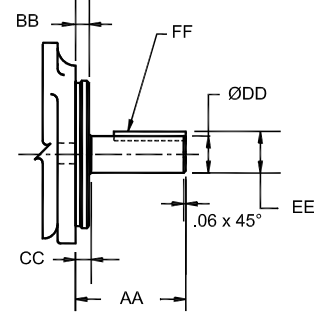

	A	B	C	ØD	E	ØF	ØH	J	ØK	M	N	P	Q	R	
BODY	2.75	1.41	2.75	1.50	0.62	5.000/4.998	3.50	4.75	1.00	2.94	5.35	4.70	1.69	3.69	
	S	T	ØV x 2	RW	W	ØX	Y	Z							
	13.0	4.03	0.69	0.63	8.38	7.13	1.03	2.06							
PORT CONN.	ØO1 x 4 Holes			ØO2 x 4 Holes			Ø I x 4 Holes			Outlet No 1 Flange		Outlet No 2 Flange		Inlet Flange	
	12"-13UNC-2B x 0.94			3/8"-16UNC-2B x 0.66			5/8"-11UNC-2B x 1.25			F1-12-		F1-8-		F1-28-	
SHAFT TYPE	Shaft Type	AA	BB	CC	ØDD	EE	FF Key Width x Length								
	1	2.44	.500	.560	1.250/1.248	1.390/1.380	.312x1.12								
	86	3.44	.500	.560	1.499/1.498	1.669/1.659	.375x2.00								
	Shaft Type	AA	BB	CC	ØDD	EE	Spline Data Code								
11	2.44	.500	.565	1.56	.38	D (See Below Chart)									
Spline Data Code	Number of Teeth	Pitch	Major Diameter	Form Diameter	Minor Diameter	Minor Diameter									
D	14	12/24	1.248/1.247	1.07	1.063/1.050	Major dia. fit									

4535VQ INSTALLATION DIMENSION

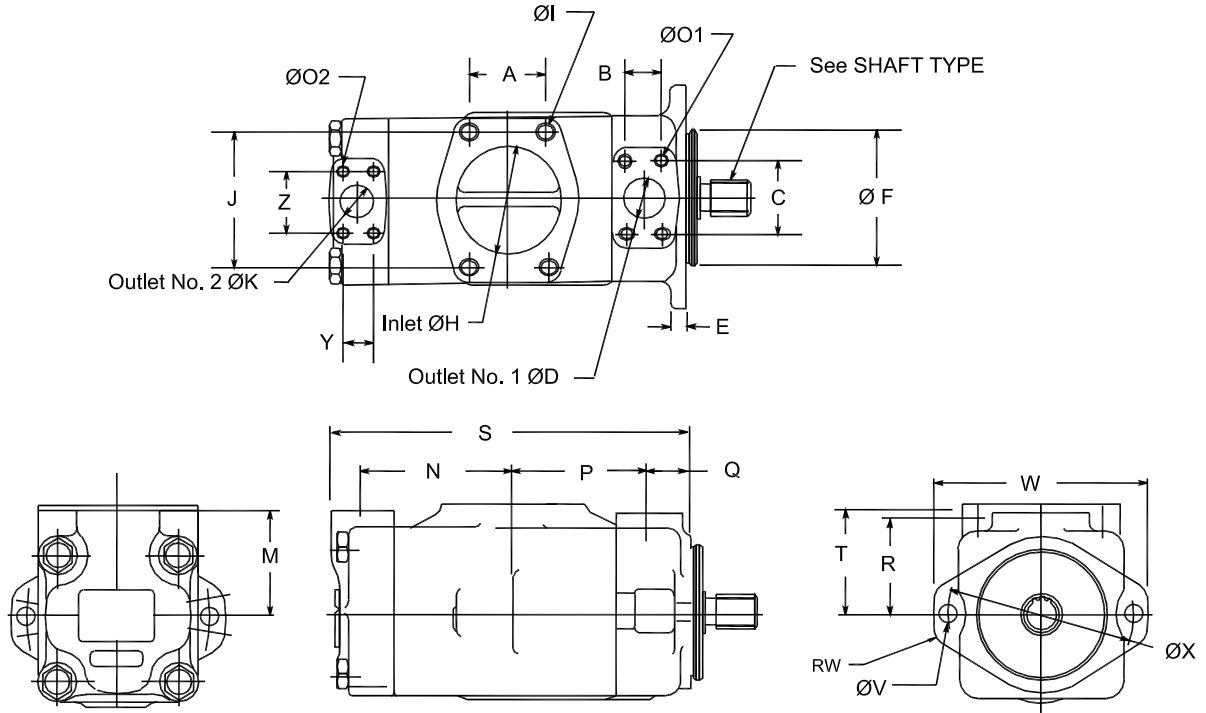

SHAFT TYPE

#1 Straight Shaft

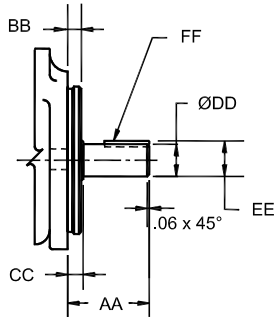

#11 Splined Shaft

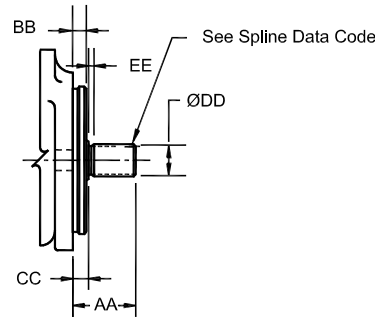

#86 Straight Shaft

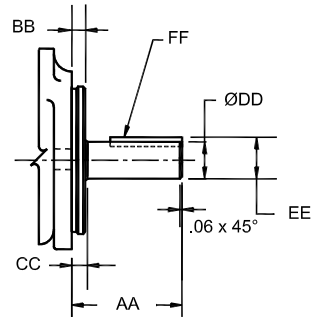

	A	B	C	øD	E	øF	øH	J	øK	M	N	P	Q	R	
BODY	3.06	1.41	2.75	1.50	0.62	5.000/4.998	4.00	5.13	1.25	4.00	5.84	5.25	1.69	3.69	
	S	T	øV x 2	RW	W	øX	Y	Z							
	13.9	4.03	0.69	0.63	8.38	7.13	1.19	2.31							
PORT CONN.	ØO1 x 4 Holes			ØO2 x 4 Holes			Ø I x 4 Holes			Outlet No 1 Flange		Outlet No 2 Flange		Inlet Flange	
	1/2"-13UNC-2B x 0.94			7/16"-14UNC-2B x 0.88			5/8"-11UNC-2B x 1.25			F1-12-		F1-10-		F1-32-	
SHAFT TYPE	Shaft Type	AA	BB	CC	øDD	EE	FF Key Width x Length								
	1	2.44	.500	.560	1.250/1.248	1.390/1.380	.312x1.12								
	86	3.44	.500	.560	1.499/1.498	1.669/1.659	.375x2.00								
	Shaft Type	AA	BB	CC	øDD	EE	Spline Data Code								
11	2.44	.500	.565	1.56	.38	D (See Below Chart)									
Spline Data Code	Number of Teeth	Pitch	Major Diameter	Form Diameter	Minor Diameter	Minor Diameter									
D	14	12/24	1.248/1.247	1.07	1.063/1.050	Major dia. fit									

(F3) - 2520VQ SV10 17 A 8 S 3 - 297 C C C 22 L

 1 2 3 4 5 6 7 8 9 10 11 12 13 14

1 Special Seals

 Omit - (Standard)
 F3 - Viton Seals

2 Double Pump Series No

 2520VQ 3520VQ 3525VQ
 4525VQ 4535VQ

3 Single Pump Series No

 V10 - (Standard)
 [S - SAE Mounting (Standard)]

4 Shaft End Pump (GPM)

 (@1200 RPM, 100 PSI)
 25**VQ 35**VQ 45**VQ

 12 25 42
 14 30 50
 17 35 60
 21 38

5 Double Pump Port Connection

 A - SAE 4-Bolt Flange (Standard)

6 Center Pump (GPM)

 (@1200 RPM, 100 PSI)
 **20VQ **25VQ **35VQ

 5 12 25
 8 14 30
 11 17 35
 12 21 38
 14

7 Single Pump Port Connection

 S - 3/4-16UNF-2B(Standard)

8 Cover End Pump (GPM)

 (@1200 RPM, 100 PSI)
 V10 - 1, 2, 3, 4, 5, 6, 7

9 Shaft Type

 297 - Splined (Standard)

10 Outlet No 1 Port Position

 (View From Cover End of Pump)
 A - Opposite Inlet
 B - 90° CCW From Inlet
 C - Inline With Inlet (Standard)
 D - 90° CW From Inlet

11 Outlet No 2 Port Position

 (View From Cover End of Pump)
 All Series Except 4535VQ
 A - 135° CCW From Inlet
 B - 45° CCW From Inlet
 C - 45° CW From Inlet (Standard)
 D - 135° CW From Inlet

Series 4535VQ

A - Opposite Inlet
 B - 90° CCW From Inlet
 C - Inline with Inlet (Standard)
 D - 90° CW From Inlet

12 Outlet No 3 Port Position

 (View From Cover End of Pump)
 A - Opposite Inlet
 B - 90° CCW From Inlet
 C - Inline With Inlet (Standard)
 D - 90° CW From Inlet

13 Design Number

 22 - (Standard)
 10 - Design Change

14 Rotation

 (View From Shaft End of Pump)
 Omit - Right Hand Rotation
 (Standard)
 L - Left Hand Rotation



NOTE: See Respective Pump Performance in VQ Pump Performance and V10 Pump Performance for Triple Pump Performance.

MAXIMUM SPEED (DEPENDENT ON V10 PUMP SIZE):

SERIES NO	2520VQSV10			3520VQSV10			3525VQSV10				
V10 PUMP (GPM)	1,2,3,4,5	6	7	1,2,3,4,5	6	7	1,2,3	4	5	6	7
MAX SPEED FOR ALL PUMPS (RPM)	2700	2200* 2500**	1900* 2200**	2500	2200* 2500**	1900* 2200**	2500	2200* 2500**	2200* 2500**	2200* 2400**	2200

SERIES NO	4525VQSV10		4535VQSV10	
V10 PUMP (GPM)	1,2,3,4,5,6	7	1,2,3,4,5,6	7
MAX SPEED FOR ALL PUMPS (RPM)	2200	2000* 2200**	2200	2100* 2200**

* With V10 Pump Pressure Over 1000 PSI
 ** With V10 Pump Pressure To 1000 PSI

MAXIMUM PRESSURE:

SERIES NO	25**VQSV**	35**VQSV**	45**VQSV**
PUMP (GPM)	12,14,17,21	25,30,35,38	42,50,60
MAX PRESSURE FOR SHAFT END PUMPS (PSI)	3000	3000	2500

SERIES NO	**20VQSV**			**25VQSV**	**35VQSV**
PUMP (GPM)	5,8,11	12	14	12,14,17,21	25,30,35,38
MAX PRESSURE FOR CENTER PUMPS (PSI)	3000	2300	2000	3000	3000

SERIES NO	****VQSV10		
PUMP (GPM)	1,2,3,4,5	6	7
MAX PRESSURE FOR COVER END PUMPS (PSI)	2500	2200	2000

2520VQSV10 INSTALLATION DIMENSION

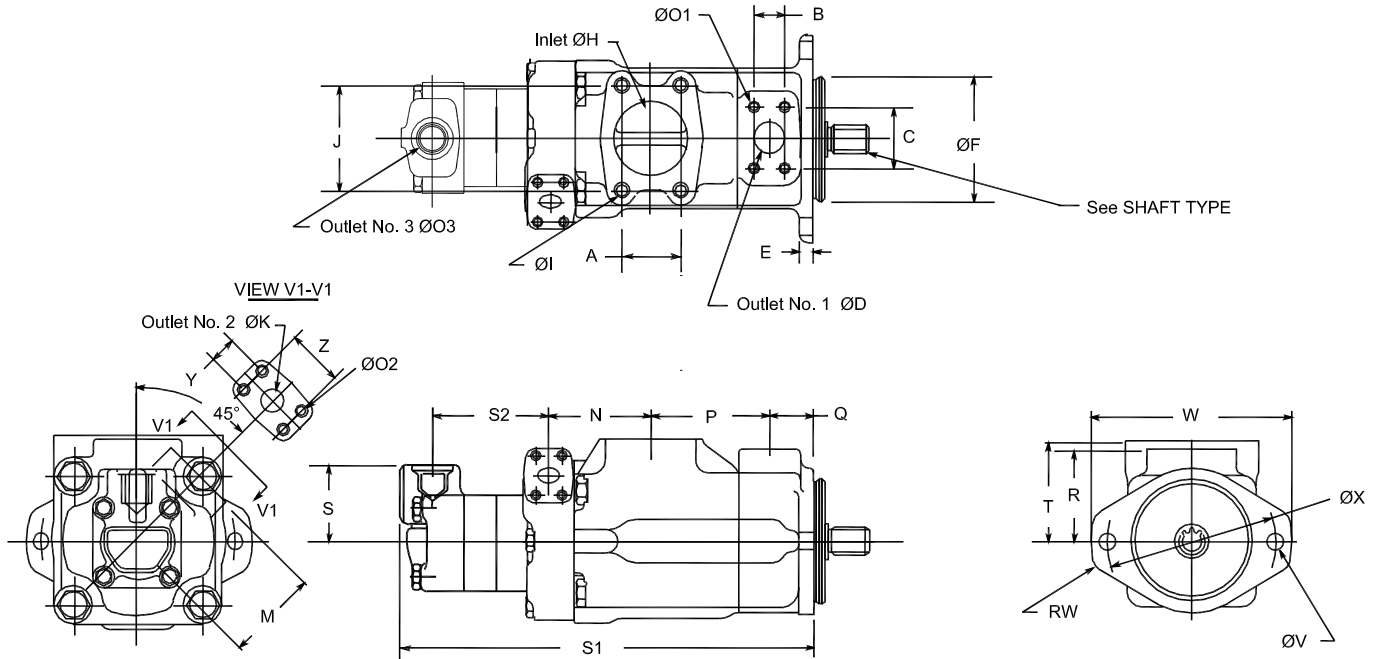

SHAFT TYPE

#297 Splined shaft

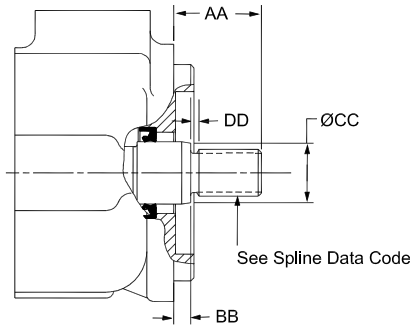

	A	B	C	øD	E	øF	øH	J	øK	M	N	P	Q	R	S	
BODY	2.00	1.03	2.06	1.00	0.50	4.000/3.998	2.50	3.50	0.75	3.00	3.47	4.00	1.50	3.00	2.47	
											V10 (GPM)		1,2,3	4,5	6,7	
	T	øV x 2	RW	W	øX	Y	Z				S1	S2	S1	S2	S1	S2
	3.31	0.56	0.55	6.88	5.75	0.88	1.88				13.78	3.43	14.03	3.68	14.23	3.88
PORT CONN.	øO1 x 4 Holes			øO2 x 4 Holes			Outlet No 3 øO3		øI x 4 Holes		Outlet No 1 Flange		Outlet No 2 Flange		Inlet Flange	
	3/8"-16UNC-2B x 0.75			3/8"-16UNC-2B x 0.75			3/4"-16UNF-2B		1/2"-13UNC-2B x 0.94		F1-8-		F1-6-		F1-20-	
SHAFT TYPE	Shaft Type	AA	BB	øCC		DD		Splines Data Code								
	297	1.62	.31	1.09		.25		C (See Below Chart)								
	Splines Data Code	Number of Teeth	Pitch	Major Diameter	Form Diameter	Minor Diameter	Minor Diameter									
	C	13	16/32	.858/.852	.749	.715	Side fit									

3520VQSV10 INSTALLATION DIMENSION

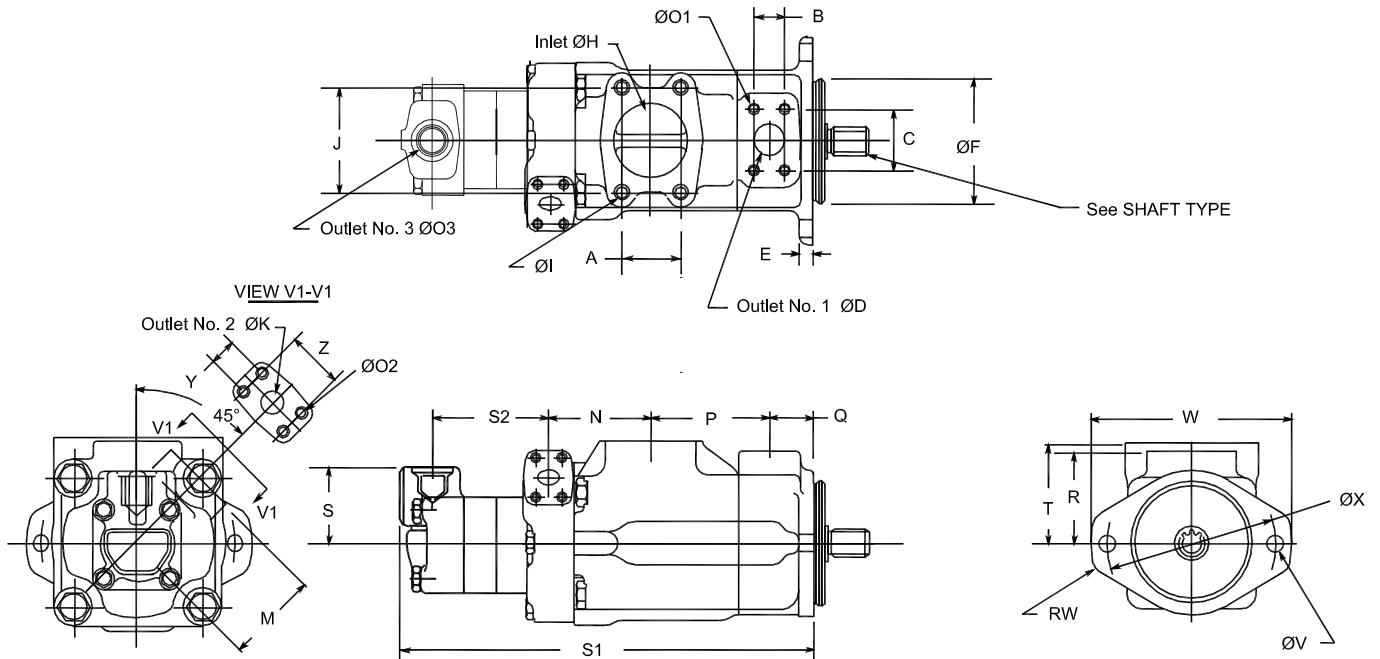

SHAFT TYPE

#297 Splined shaft

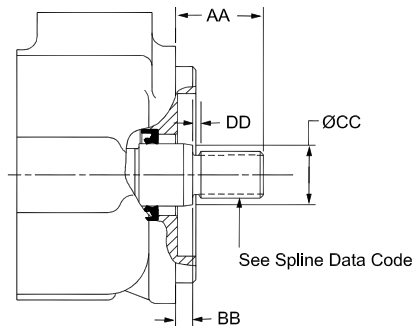

	A	B	C	øD	E	øF	øH	J	øK	M	N	P	Q	R	S	
BODY	2.44	1.19	2.31	1.25	0.62	5.000/4.998	3.00	4.19	0.75	3.00	3.92	4.50	1.50	3.25	2.47	
											V10 (GPM)		1.2,3	4.5	6.7	
	T	øV x 2	RW	W	øX	Y	Z				S1	S2	S1	S2	S1	S2
	3.50	0.69	0.63	8.38	7.13	0.88	1.88				14.66	3.43	14.91	3.68	15.11	3.88
PORT CONN.	øO1 x 4 Holes		øO2 x 4 Holes		Outlet No 3 øO3		øI x 4 Holes		Outlet No 1 Flange		Outlet No 2 Flange		Inlet Flange			
	7/16"-14UNC-2B x 0.88		3/8"-16UNC-2B x 0.75		3/4"-16UNF-2B		5/8"-11UNC-2B x 1.125		F1-10-		F1-6-		F1-24-			
SHAFT TYPE	Shaft Type	AA	BB	øCC	DD	Spline Data Code										
	297	2.18	.31	1.38	.21	E (See Below Chart)										
	Spline Data Code	Number of Teeth	Pitch	Major Diameter	Form Diameter	Minor Diameter	Minor Diameter									
	E	14	12/24	1.229/1.223	1.08	1.040	Side fit									

3525VQSV10 INSTALLATION DIMENSION

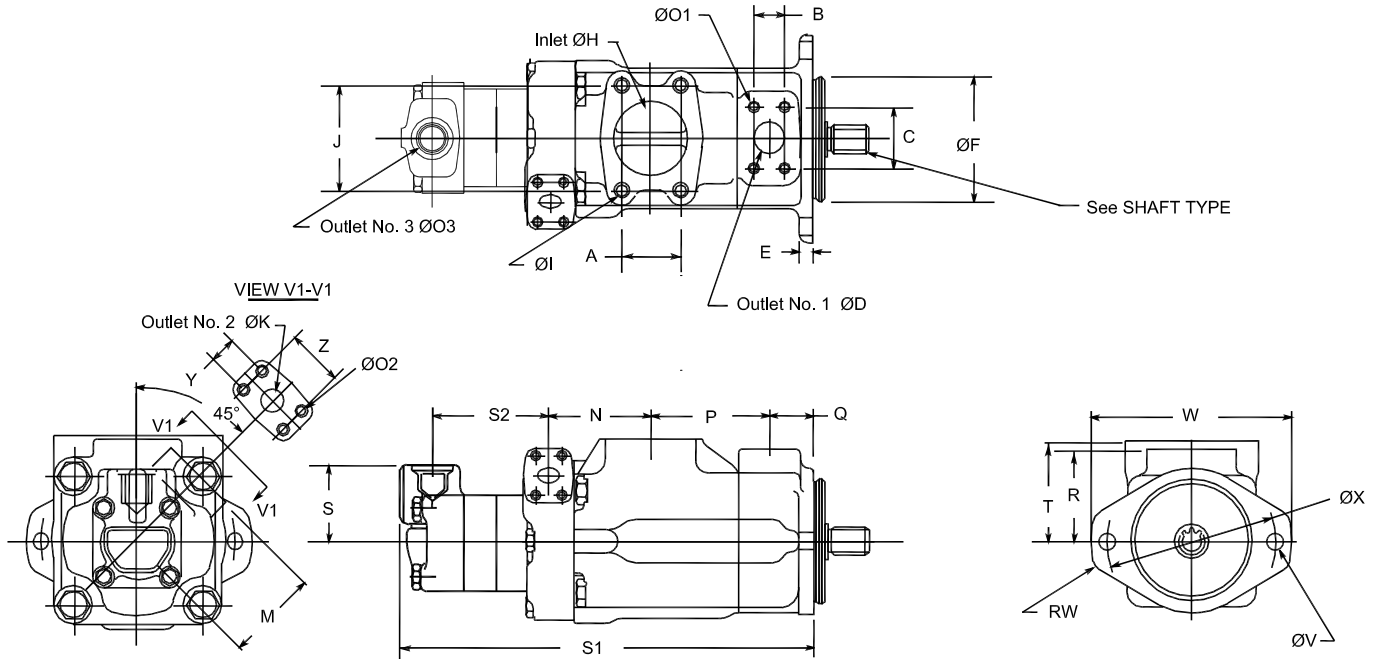

SHAFT TYPE

#297 Splined shaft

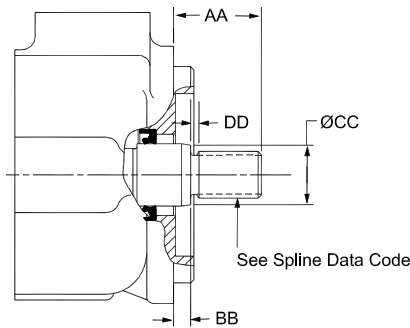

BODY	A	B	C	ØD	E	ØF	ØH	J	ØK	M	N	P	Q	R	S	
		2.44	1.19	2.31	1.25	0.62	5.000/4.998	3.00	4.19	1.00	2.94	4.31	4.50	1.50	3.25	2.47
											V10 (GPM)		1,2,3	4,5	6,7	
	T	ØV x 2	RW	W	ØX	Y	Z				S1	S2	S1	S2	S1	S2
	3.50	0.69	0.63	8.38	7.13	1.03	2.06				15.00	3.40	15.25	3.65	15.45	3.85

PORT CONN.	ØO1 x 4 Holes	ØO2 x 4 Holes	Outlet No 3 ØO3	Ø I x 4 Holes	Outlet No 1 Flange	Outlet No 2 Flange	Inlet Flange
		7/16"-14UNC-2B x 0.88	3/8"-16UNC-2B x 0.66	3/4"-16UNF-2B	5/8"-11UNC-2B x 1.125	F1-10-	F1-8-

SHAFT TYPE	Shaft Type	AA	BB	ØCC	DD	Spline Data Code	
		297	2.18	.31	1.38	.21	E (See Below Chart)
	Spline Data Code	Number of Teeth	Pitch	Major Diameter	Form Diameter	Minor Diameter	Minor Diameter
	E	14	12/24	1.229/1.223	1.08	1.040	Side fit

4525VQSV10 INSTALLATION DIMENSION

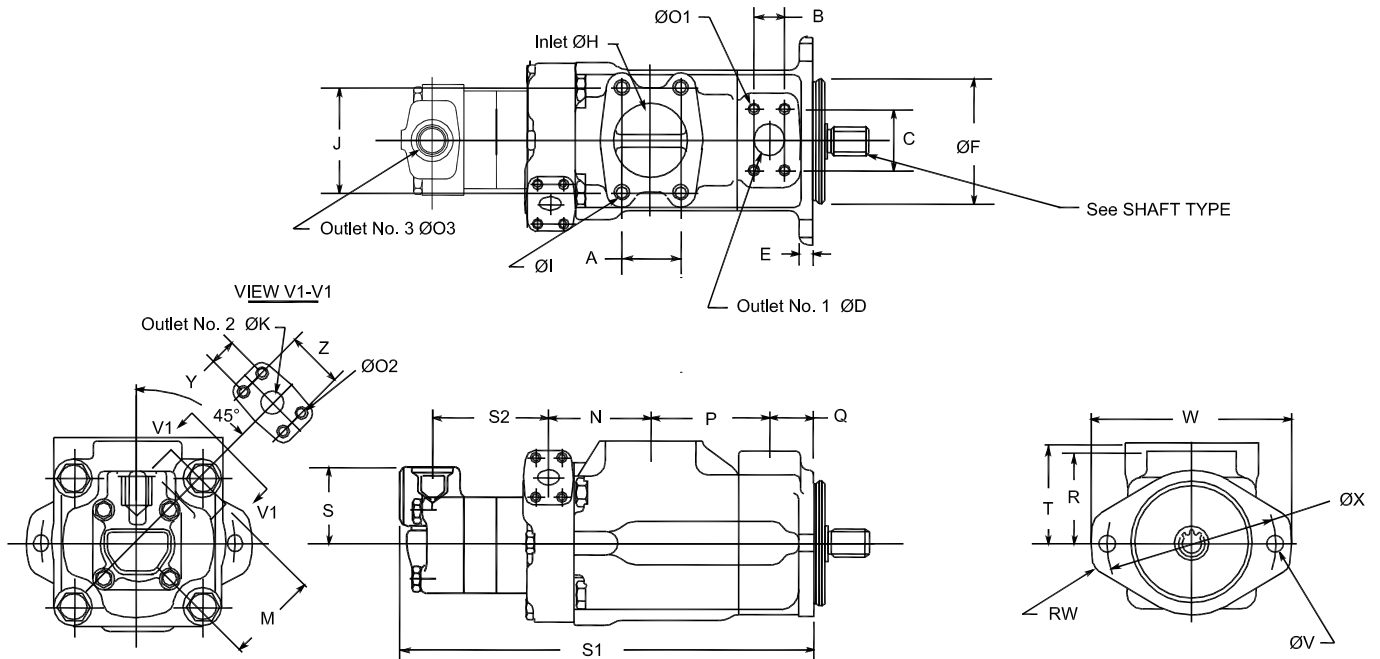

SHAFT TYPE

#297 Splined shaft

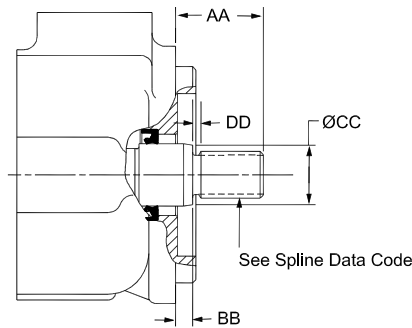

BODY	A	B	C	øD	E	øF	øH	J	øK	M	N	P	Q	R	S	
	2.75	1.41	2.75	1.50	0.62	5.000/4.998	3.50	4.75	1.00	2.94	5.35	4.70	1.69	3.69	2.47	
											V10 (GPM)		1,2,3	4,5	6,7	
	T	øV x 2	RW	W	øX	Y	Z				S1	S2	S1	S2	S1	S2
	4.03	0.69	0.63	8.38	7.13	1.03	2.06				16.53	3.40	16.78	3.65	16.98	3.85

PORT CONN.	øO1 x 4 Holes	øO2 x 4 Holes	Outlet No 3 øO3	øI x 4 Holes	Outlet No 1 Flange	Outlet No 2 Flange	Inlet Flange
		1/2"-13UNC-2B x 0.94	3/8"-16UNC-2B x 0.66	3/4"-16UNF-2B	5/8"-11UNC-2B x 1.25	F1-12-	F1-8-

SHAFT TYPE	Shaft Type	AA	BB	øCC	DD	Splines Data Code	
	297	2.18	.31	1.56	.25	E (See Below Chart)	
	Splines Data Code	Number of Teeth	Pitch	Major Diameter	Form Diameter	Minor Diameter	Minor Diameter
E	14	12/24	1.229/1.223	1.08	1.040	Side fit	

4535VQSV10 INSTALLATION DIMENSION

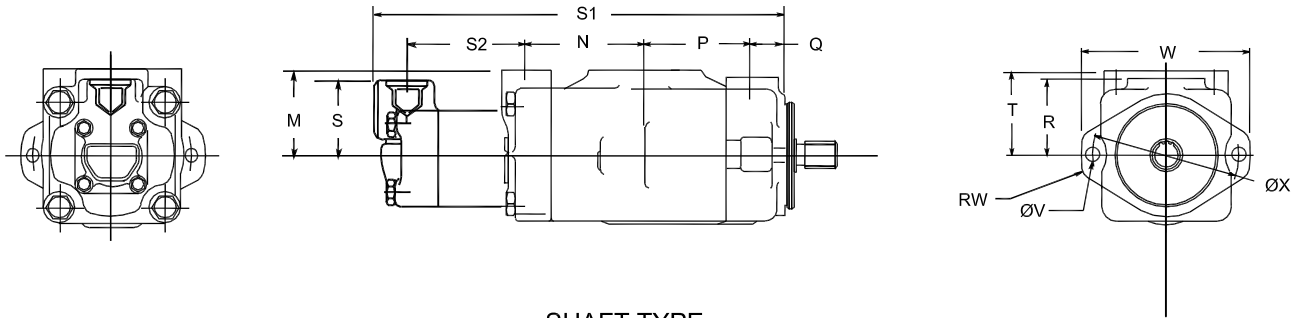
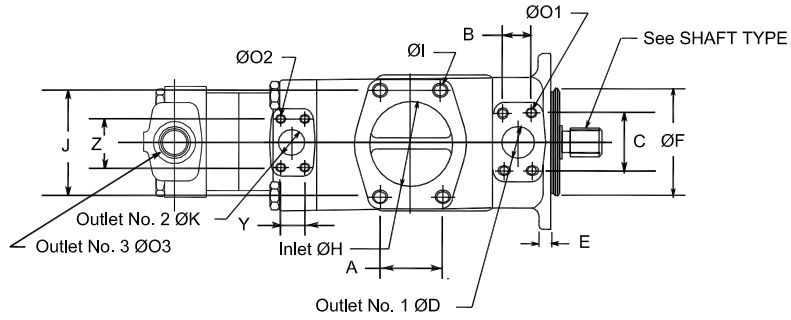

SHAFT TYPE

#297 Splined shaft

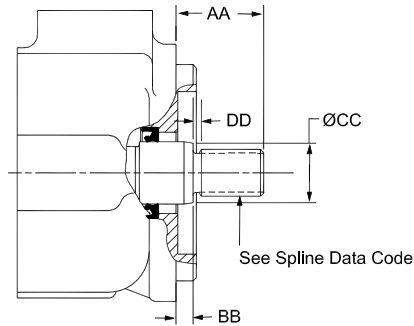

	A	B	C	øD	E	øF	øH	J	øK	M	N	P	Q	R	S		
BODY	3.06	1.41	2.75	1.50	0.62	5.000/4.998	4.00	5.13	1.25	4.00	5.84	5.25	1.69	3.69	2.47		
										V10 (GPM)		1,2,3		4,5		6,7	
	T	øV x 2	RW	W	øX	Y	Z			S1	S2	S1	S2	S1	S2		
	4.03	0.69	0.63	8.38	7.13	1.19	2.31			17.50	3.31	17.75	3.56	17.95	3.76		
PORT CONN.	ØO1 x 4 Holes			ØO2 x 4 Holes			Outlet No 3 ØO3		Ø I x 4 Holes		Outlet No 1 Flange		Outlet No 2 Flange		Inlet Flange		
	1/2"-13UNC-2B x 0.94			7/16"-14UNC-2B x 0.88			3/4"-16UNF-2B		5/8"-11UNC-2B x 1.25		F1-12-		F1-10-		F1-32-		
SHAFT TYPE	Shaft Type	AA	BB	øCC	DD	Spline Data Code											
	297	2.18	.31	1.56	.25	E (See Below Chart)											
	Spline Data Code	Number of Teeth	Pitch	Major Diameter	Form Diameter	Minor Diameter	Minor Diameter										
E	14	12/24	1.229/1.223	1.08	1.040	Side fit											

(F3) - 25VQH 17 A - 1 C 22 L

 1 2 3 4 5 6 7 8

1 Special Seals

 Omit - (Standard)
 F3 - Viton Seals

2 Series No

 25VQH 35VQH 45VQH

3 Pump (GPM)

 (@1200 RPM, 100 PSI)

25VQ	35VQ	45VQ
10	25	42
12	30	47
14	32	50
17	35	57
19	38	60
21		

4 Port Connection

 A - SAE 4-Bolt Flange (Standard)

5 Shaft Type

 1 - Straight Keyed (Standard)
 11 - Splined
 86 - Straight Keyed

6 Outlet Port Position

 (View From Cover End of Pump)
 A - Opposite Inlet
 B - 90° CCW From Inlet
 C - Inline With Inlet (Standard)
 D - 90° CW From Inlet

7 Design Number

 22 - (Standard)
 10 - Design Change

8 Rotation

 (View From Shaft End of Pump)
 Omit - Right Hand Rotation
 (Standard)
 L - Left Hand Rotation



ITEM	25VQH		35VQH		45VQH	
	10,12,14	17,19,21	25,30	32,35,38	42,47,50,57	60
MAX SPEED (RPM)	2700	2500	2500	2400	2200	
MAX CONTINUOUS PRESSURE (PSI)	3500		3300		3300	3000
MAX PEAK PRESSURE (PSI)	3800		3600		3600	

(F3) - 2520VQH 17 A 11 - 1 C C 22 L

 1 2 3 4 5 6 7 8 9 10

1 Special Seals

Omit - (Standard)
 F3 - Viton Seals

2 Series No

2520VQH 3520VQH 3525VQH
 4520VQH 4525VQH 4535VQH

3 Shaft End Pump (GPM)

(@1200 RPM, 100 PSI)

25**VQH 35**VQH 45**VQH

10 25 42
 12 30 47
 14 32 50
 17 35 57
 19 38 60
 21

4 Port Connection

A - SAE 4-Bolt Flange (Standard)

5 Cover End Pump (GPM)

(@1200 RPM, 100 PSI)

**20VQH **25VQH **35VQH

2 10 25
 5 12 30
 8 14 32
 9 17 35
 11 19 38
 12 21
 14

6 Shaft Type

1 - Straight Keyed (Standard)
 11 - Splined
 86 - Straight Keyed (Heavy Duty)

7 Outlet No 1 Port Position

(View From Cover End of Pump)

A - Opposite Inlet
 B - 90° CCW From Inlet
 C - Inline With Inlet (Standard)
 D - 90° CW From Inlet

8 Outlet No 2 Port Position

(View From Cover End of Pump)
 All Series Except 4535VQH

A - 135° CCW From Inlet
 B - 45° CCW From Inlet
 C - 45° CW From Inlet (Standard)
 D - 135° CW From Inlet

Series 4535VQH

A - Opposite Inlet
 B - 90° CCW From Inlet
 C - Inline with Inlet (Standard)
 D - 90° CW From Inlet

9 Design Number

22 - (Standard)
 10 - Design Change

10 Rotation

(View From Shaft End of Pump)
 Omit - Right Hand Rotation
 (Standard)
 L - Left Hand Rotation



ITEM	**20VQH		25**VQH **25VQH		35**VQH **35VQH		45**VQH	
	5,8,11,12	14	10,12,14	17,19,21	25,30	32,35,38	42,47,50,57	60
MAX SPEED (RPM)	2700		2700	2500	2500	2400	2200	
MAX CONTINUOUS PRESSURE (PSI)	3300	3000	3500		3300		3300	3000

25VQH INSTALLATION DIMENSION

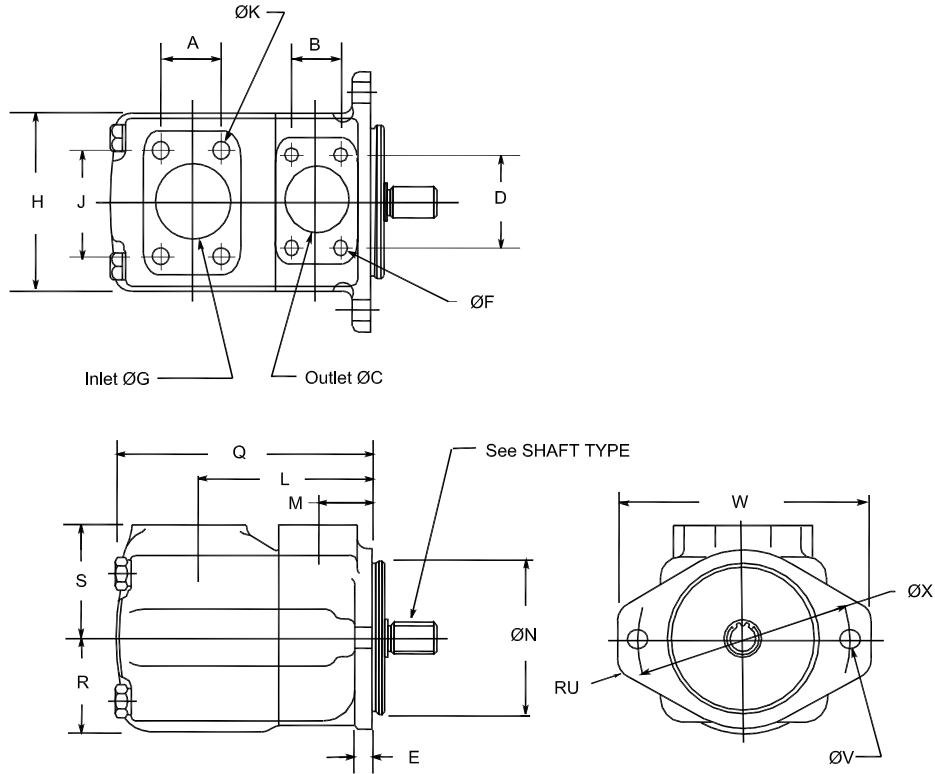

SHAFT TYPE

#1 Straight Shaft

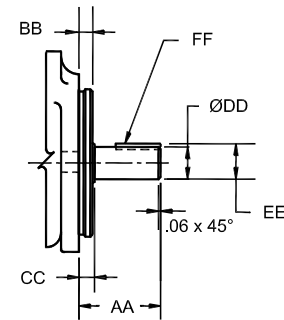

#11 Splined Shaft

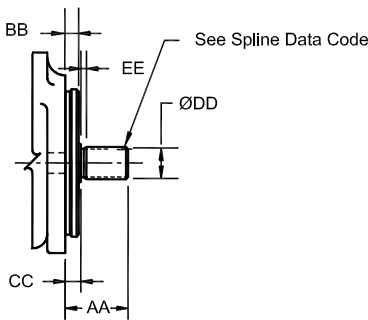

#86 Straight Shaft

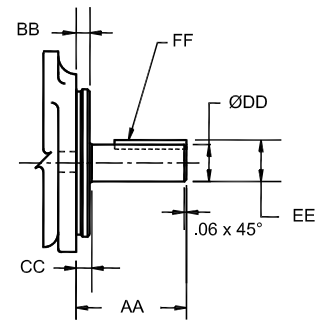

BODY	A	B	ØC	D	E	ØG	H	J	L	M	ØN
	1.41	1.03	1.00	2.06	0.50	1.50	4.62	2.75	4.76	1.50	4.000/3.998
PORT CONN.	Q		R	S	RU		ØV x 2	W	ØX		
	6.38	2.50	3.00	0.55	0.56	6.88	5.75				
SHAFT TYPE	ØF x 4 Holes		ØK x 4 Holes		Outlet Flange		Inlet Flange				
	3/8"-16UNC-2B x 0.75		1/2"-13UNC-2B x 0.94		F1-8-		F1-12-				
SHAFT TYPE	Shaft Type	AA	BB	CC	ØDD		EE	FF Key Width x Length			
	1	2.32	.375	.435	.875/.874		.966/.961	.187x1.25			
	86	3.06	.375	.435	.999/.998		1.11/1.10	.250x2.00			
	Shaft Type	AA	BB	CC	ØDD	EE	Spline Data Code				
11	1.75	.375	.437	1.09	.156	A (See Below Chart)					
Spline Data Code	Number of Teeth	Pitch	Major Diameter	Form Diameter	Minor Diameter	Minor Diameter					
A	13	16/32	.873/.872	.749	.734/.723	Major dia. fit					

35VQH INSTALLATION DIMENSION

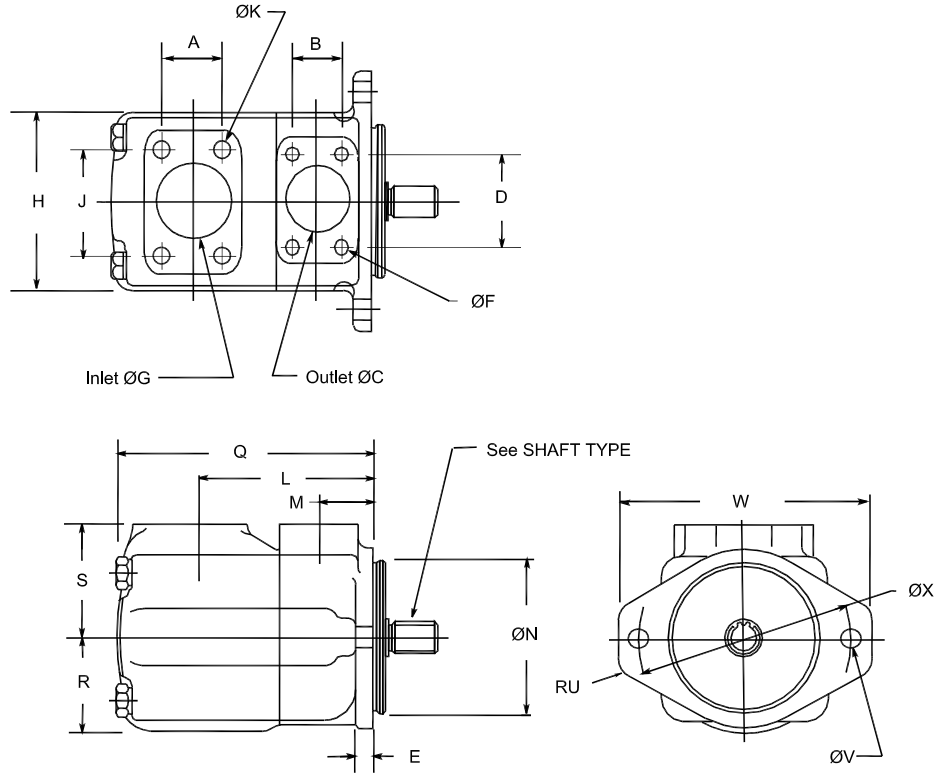

SHAFT TYPE

#1 Straight Shaft

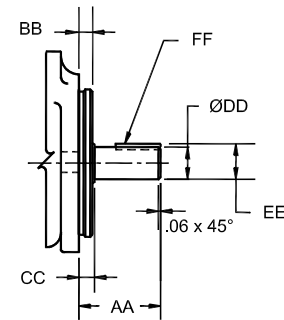

#11 Splined Shaft

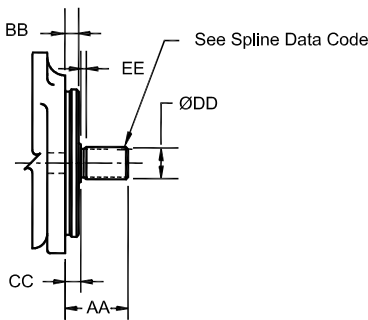

#86 Straight Shaft

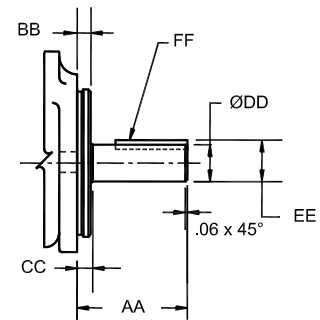

	A	B	ØC	D	E	ØG	H	J	L	M	ØN	
BODY	1.69	1.19	1.25	2.31	0.63	2.00	5.50	3.06	4.94	1.50	5.000/4.998	
	Q	R	S	RU	ØV x 2	W	ØX					
	7.28	2.75	3.25	0.63	0.69	8.38	7.13					
PORT CONN.	ØF x 4 Holes			ØK x 4 Holes			Outlet Flange		Inlet Flange			
	7/16"-14UNC-2B x 0.88			1/2 "-13UNC-2B x 0.88			F1-10-		F1-16-			
SHAFT TYPE	Shaft Type	AA	BB	CC	ØDD	EE	FF Key Width x Length					
	1	2.88	.375	.437	1.250/1.248	1.392/1.382	.313x1.50					
	86	3.88	.375	.437	1.374/1.373	1.518/1.508	.312x2.13					
	Shaft Type	AA	BB	CC	ØDD	EE	Spline Data Code					
11	2.31	.375	.437	1.38	.25	D (See Below Chart)						
Spline Data Code	Number of Teeth	Pitch	Major Diameter	Form Diameter	Minor Diameter	Minor Diameter						
D	14	12/24	1.248/1.247	1.07	1.063/1.050	Major dia. fit						

45VQH INSTALLATION DIMENSION

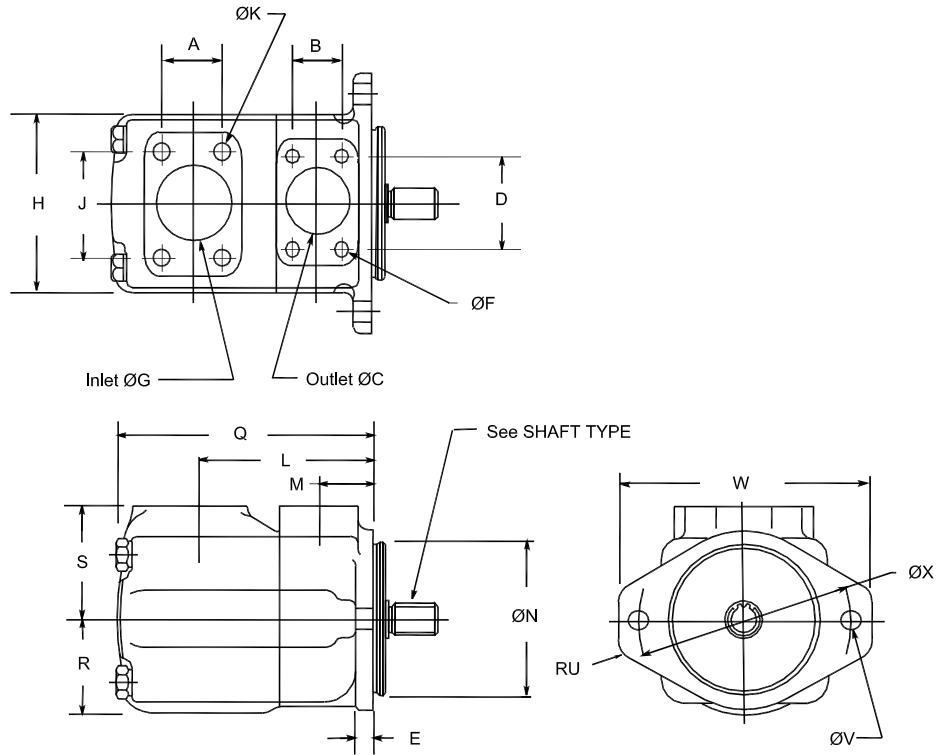

SHAFT TYPE

#1 Straight Shaft

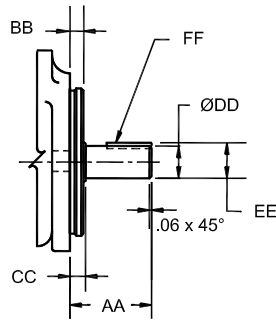

#11 Splined Shaft

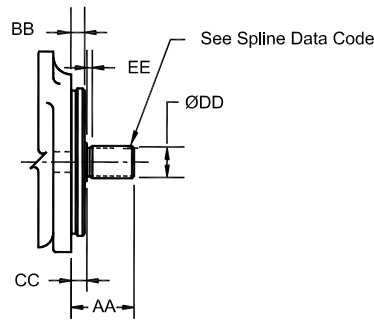

#86 Straight Shaft

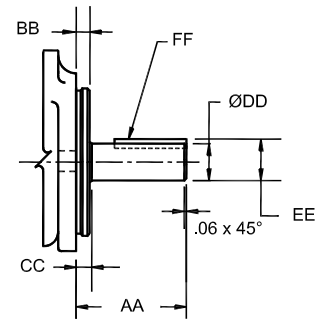

	A	B	ØC	D	E	ØG	H	J	L	M	ØN	
BODY	2.43	1.41	1.50	2.75	0.63	3.00	6.25	4.19	6.03	1.69	5.000/4.998	
	Q	R	S	RU	ØV x 2	W	ØX					
	8.50	3.25	3.69	0.63	0.69	8.38	7.13					
PORT CONN.	ØF x 4 Holes			ØK x 4 Holes			Outlet Flange		Inlet Flange			
	1/2"-13UNC-2B x 0.94			5/8 "-11UNC-2B x 1.18			F1-12-		F1-24-			
SHAFT TYPE	Shaft Type	AA	BB	CC	ØDD	EE	FF Key Width x Length					
	1	2.44	.500	.560	1.250/1.248	1.390/1.380	.312x1.12					
	86	3.44	.500	.560	1.499/1.498	1.669/1.659	.375x2.00					
	Shaft Type	AA	BB	CC	ØDD	EE	Spline Data Code					
	11	2.44	.500	.565	1.56	.38	D (See Below Chart)					
Spline Data Code	Number of Teeth	Pitch	Major Diameter	Form Diameter	Minor Diameter	Minor Diameter						
D	14	12/24	1.248/1.247	1.07	1.063/1.050	Major dia. fit						

2520VQH INSTALLATION DIMENSION

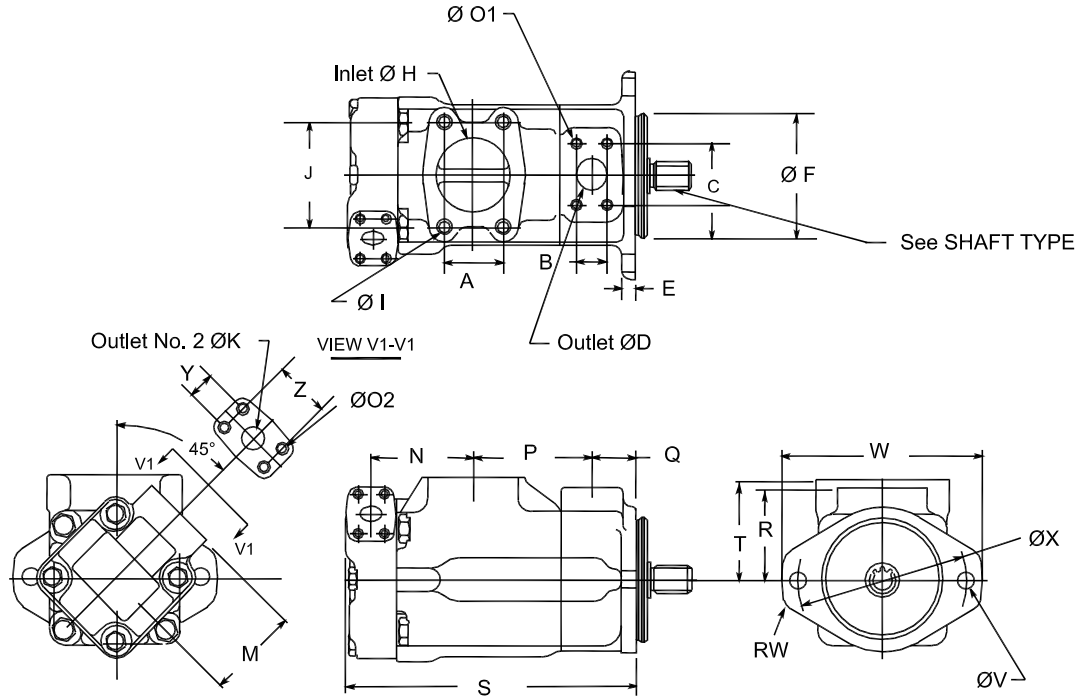

SHAFT TYPE

#1 Straight Shaft

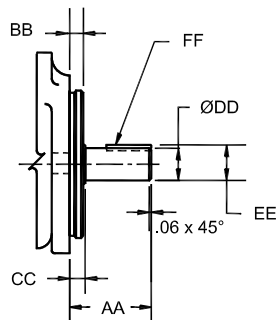

#11 Splined Shaft

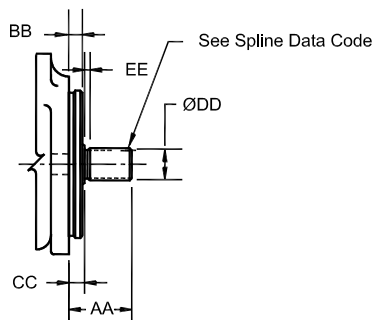

#86 Straight Shaft

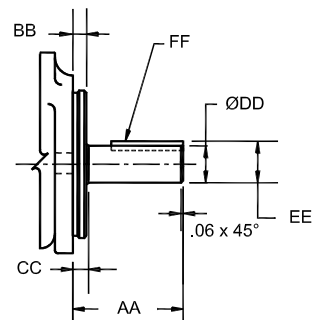

BODY	A	B	C	øD	E	øF	øH	J	øK	M	N	P	Q	R
		2.00	1.03	2.06	1.00	0.50	4.000/3.998	2.50	3.50	0.75	3.00	3.47	4.00	1.50
PORT CONN.	S	T	øV x 2	RW	W	øX	Y	Z						
	9.94	3.31	0.56	0.55	6.88	5.75	0.88	1.88						
SHAFT TYPE	øO1 x 4 Holes		øO2 x 4 Holes		øI x 4 Holes		Outlet No 1 Flange		Outlet No 2 Flange		Inlet Flange			
	3/8"-16UNC-2B x 0.75		3/8"-16UNC-2B x 0.75		1/2"-13UNC-2B x 0.94		F1-8-		F1-6-		F1-20-			
	Shaft Type	AA	BB	CC	øDD	EE	FF Key Width x Length							
	1	2.32	.375	.435	.875/.874	.966/.961	.187x1.25							
86	3.06	.375	.435	.999/.998	1.11/1.10	.250x2.00								
Shaft Type	AA	BB	CC	øDD	EE	Spline Data Code								
11	1.75	.375	.437	1.09	.156	A (See Below Chart)								
Spline Data Code	Number of Teeth	Pitch	Major Diameter	Form Diameter	Minor Diameter	Minor Diameter								
A	13	16/32	.873/.872	.749	.734/.723	Major dia. fit								

3520VQH INSTALLATION DIMENSION

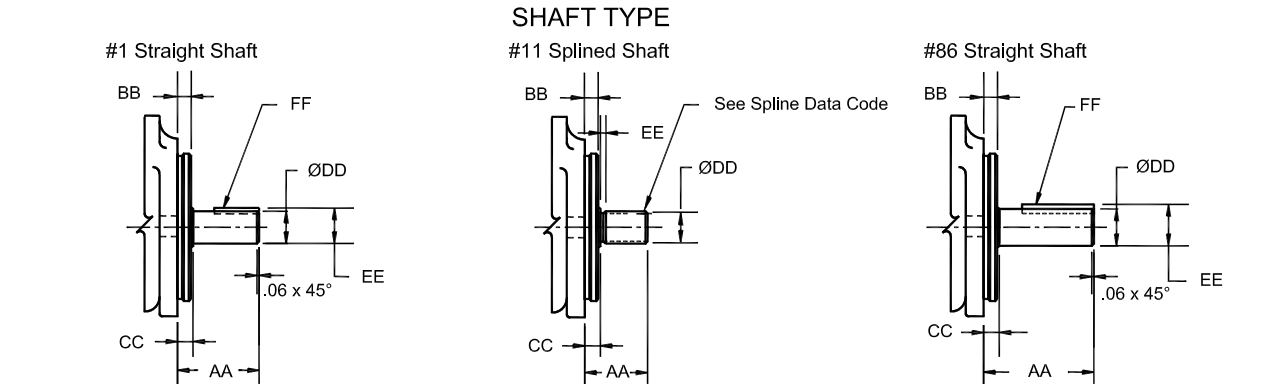
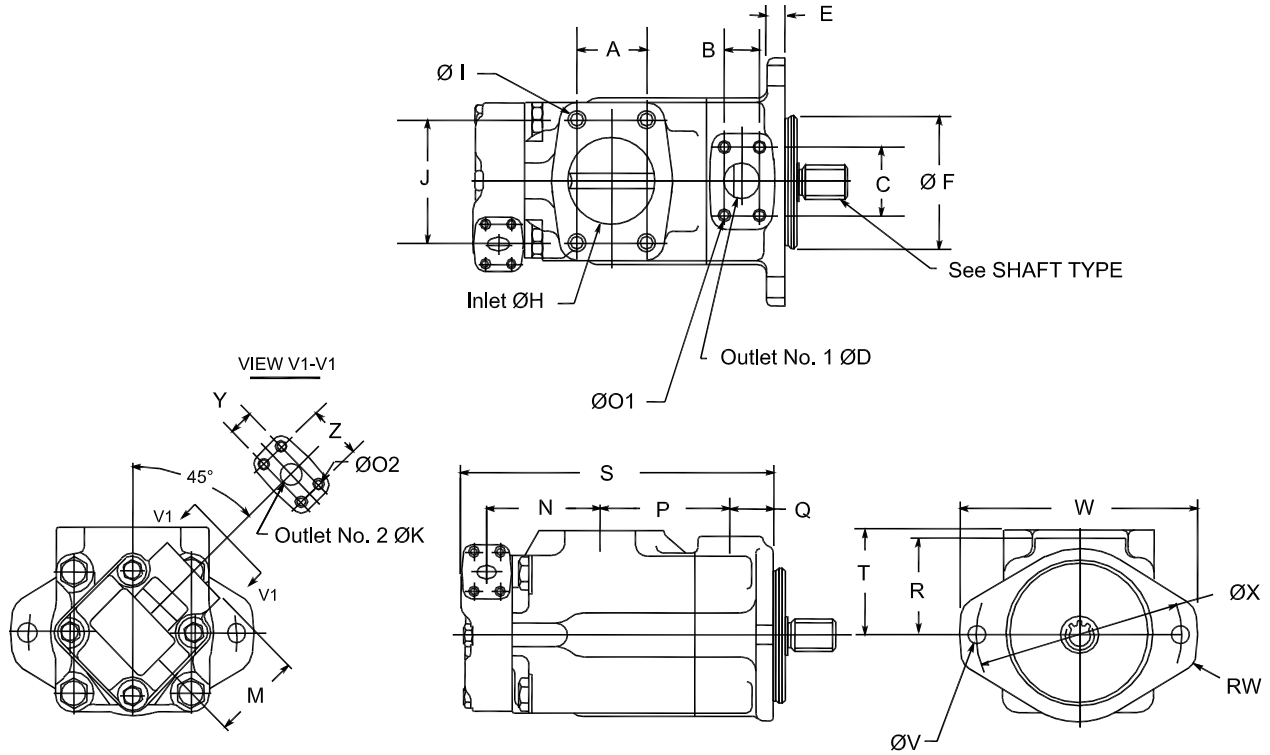

	A	B	C	ØD	E	ØF	ØH	J	ØK	M	N	P	Q	R
BODY	2.44	1.19	2.31	1.25	0.62	5.000/4.998	3.00	4.19	0.75	3.00	3.92	4.50	1.50	3.25
	S	T	ØV x 2	RW	W	ØX	Y	Z						
	10.9	3.50	0.69	0.63	8.38	7.13	0.88	1.88						
PORT CONN.	ØO1 x 4 Holes			ØO2 x 4 Holes			ØI x 4 Holes			Outlet No 1 Flange		Outlet No 2 Flange		Inlet Flange
	7/16"-14UNC-2B x 0.88			3/8"-16UNC-2B x 0.75			5/8"-11UNC-2B x 1.125			F1-10-		F1-6-		F1-24-
SHAFT TYPE	Shaft Type	AA	BB	CC	ØDD	EE	FF Key Width x Length							
	1	2.88	.375	.435	1.250/1.248	1.392/1.382	.313x1.50							
	86	3.88	.375	.435	1.374/1.373	1.518/1.508	.312x2.13							
	Shaft Type	AA	BB	CC	ØDD	EE	Spline Data Code							
11	2.31	.375	.437	1.38	.25	D (See Below Chart)								
Spline Data Code	Number of Teeth	Pitch	Major Diameter	Form Diameter	Minor Diameter	Minor Diameter								
D	14	12/24	1.248/1.247	1.07	1.063/1.050	Major dia. fit								

3525VQH INSTALLATION DIMENSION

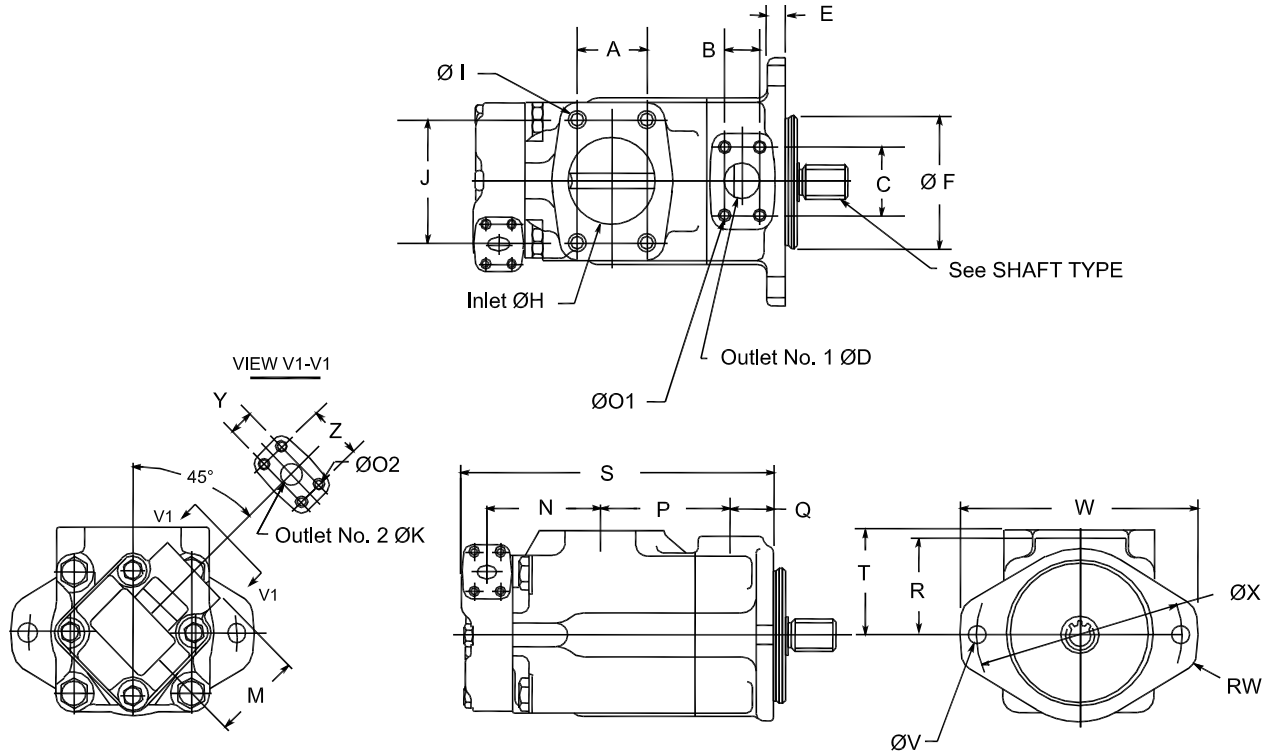

#1 Straight Shaft

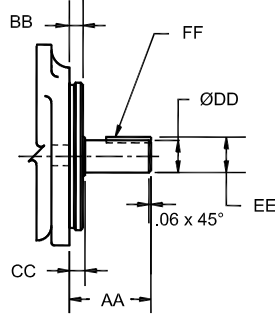

SHAFT TYPE

#11 Splined Shaft

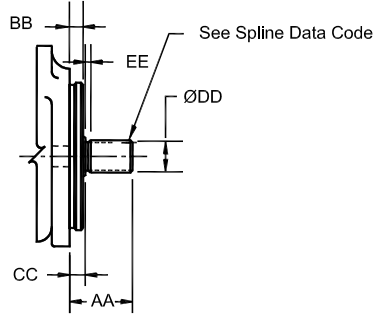

#86 Straight Shaft

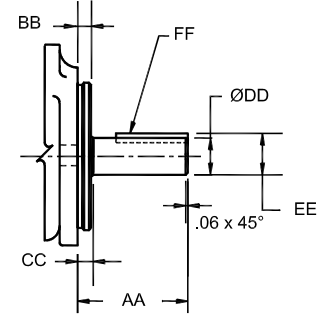

BODY	A	B	C	øD	E	øF	øH	J	øK	M	N	P	Q	R
		2.44	1.19	2.31	1.25	0.62	5.000/4.998	3.00	4.19	1.00	2.94	4.31	4.50	1.50
PORT CONN.	S	T	øV x 2	RW	W	øX	Y	Z						
	11.57	3.50	0.69	0.63	8.38	7.13	1.03	2.06						
SHAFT TYPE	øO1 x 4 Holes		øO2 x 4 Holes		øI x 4 Holes			Outlet No 1 Flange		Outlet No 2 Flange		Inlet Flange		
	7/16"-14UNC-2B x 0.88		3/8"-16UNC-2B x 0.66		5/8"-11UNC-2B x 1.125			F1-10-		F1-8-		F1-24-		
SHAFT TYPE	Shaft Type	AA	BB	CC	øDD	EE	FF Key Width x Length							
	1	2.88	.375	.435	1.250/1.248	1.392/1.382	.313x1.50							
	86	3.88	.375	.435	1.374/1.373	1.518/1.508	.312x2.13							
	Shaft Type	AA	BB	CC	øDD	EE	Spline Data Code							
11	2.31	.375	.437	1.38	.25	D (See Below Chart)								
Spline Data Code	Number of Teeth	Pitch	Major Diameter	Form Diameter	Minor Diameter	Minor Diameter								
D	14	12/24	1.248/1.247	1.07	1.063/1.050	Major dia. fit								

4520VQH INSTALLATION DIMENSION

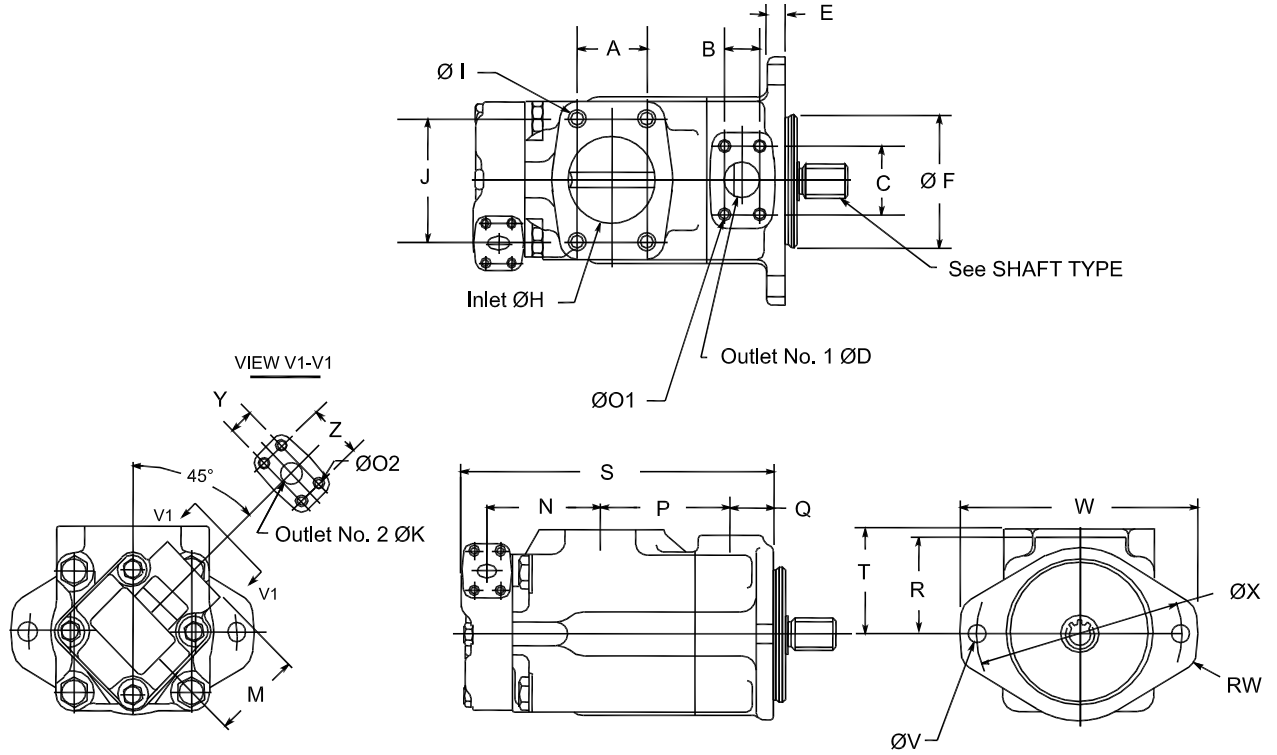

#1 Straight Shaft

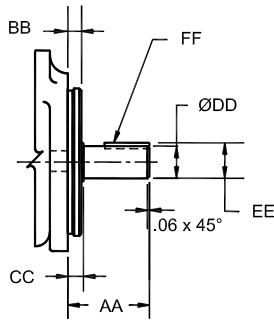

SHAFT TYPE

#11 Splined Shaft

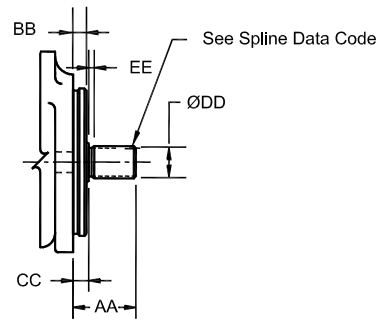

#86 Straight Shaft

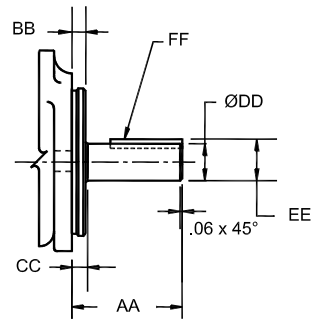

	A	B	C	øD	E	øF	øH	J	øK	M	N	P	Q	R	
BODY	2.75	1.41	2.75	1.50	0.62	5.000/4.998	3.50	4.75	0.75	3.00	4.72	4.70	1.69	3.69	
	S	T	øV x 2	RW	W	øX	Y	Z							
	12.08	4.03	0.69	0.63	8.38	7.13	0.88	1.88							
PORT CONN.	ØO1 x 4 Holes			ØO2 x 4 Holes			Ø I x 4 Holes			Outlet No 1 Flange		Outlet No 2 Flange		Inlet Flange	
	12"-13UNC-2B x 0.94			3/8"-16UNC-2B x 0.75			5/8"-11UNC-2B x 1.25			F1-12-		F1-6-		F1-28-	
SHAFT TYPE	Shaft Type	AA	BB	CC	øDD	EE	FF Key Width x Length								
	1	2.44	.500	.560	1.250/1.248	1.390/1.380	.312x1.12								
	86	3.44	.500	.560	1.499/1.498	1.669/1.659	.375x2.00								
	Shaft Type	AA	BB	CC	øDD	EE	Spline Data Code								
11	2.44	.500	.565	1.56	.38	D (See Below Chart)									
Spline Data Code	Number of Teeth	Pitch	Major Diameter	Form Diameter	Minor Diameter	Minor Diameter									
D	14	12/24	1.248/1.247	1.07	1.063/1.050	Major dia. fit									

4525VQH INSTALLATION DIMENSION

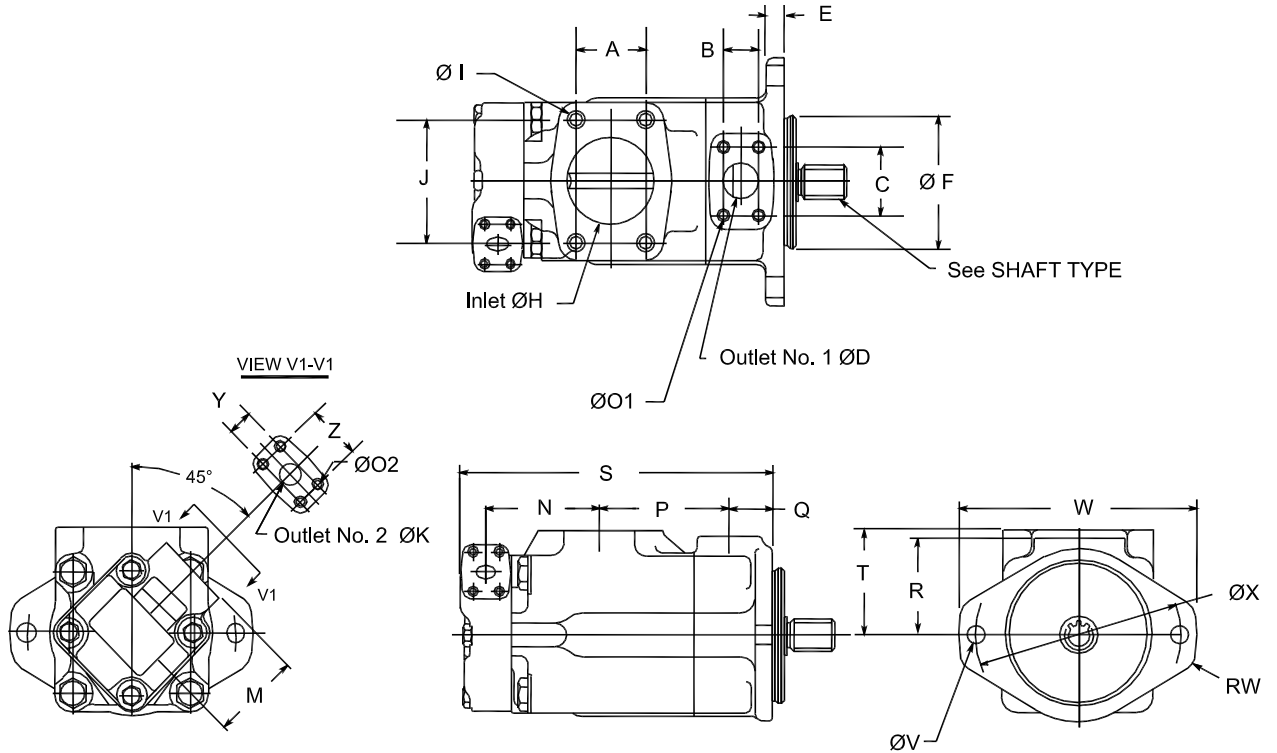

#1 Straight Shaft

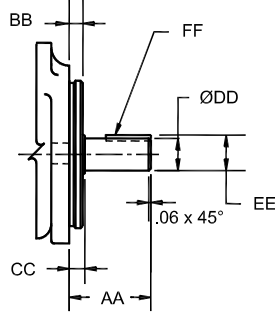

SHAFT TYPE

#11 Splined Shaft

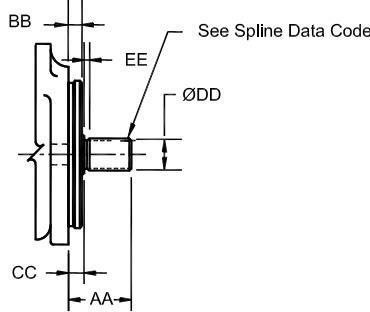

#86 Straight Shaft

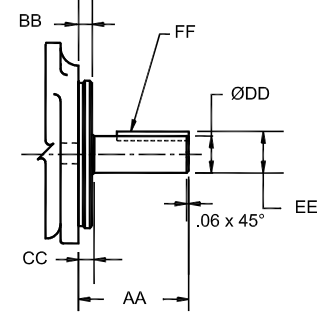

	A	B	C	ØD	E	ØF	ØH	J	ØK	M	N	P	Q	R	
BODY	2.75	1.41	2.75	1.50	0.62	5.000/4.998	3.50	4.75	1.00	2.94	5.35	4.70	1.69	3.69	
	S	T	ØV x 2	RW	W	ØX	Y	Z							
	13.0	4.03	0.69	0.63	8.38	7.13	1.03	2.06							
PORT CONN.	ØO1 x 4 Holes			ØO2 x 4 Holes			Ø I x 4 Holes			Outlet No 1 Flange		Outlet No 2 Flange		Inlet Flange	
	12"-13UNC-2B x 0.94			3/8"-16UNC-2B x 0.66			5/8"-11UNC-2B x 1.25			F1-12-		F1-8-		F1-28-	
SHAFT TYPE	Shaft Type	AA	BB	CC	ØDD	EE	FF Key Width x Length								
	1	2.44	.500	.560	1.250/1.248	1.390/1.380	.312x1.12								
	86	3.44	.500	.560	1.499/1.498	1.669/1.659	.375x2.00								
	Shaft Type	AA	BB	CC	ØDD	EE	Spline Data Code								
11	2.44	.500	.565	1.56	.38	D (See Below Chart)									
Spline Data Code	Number of Teeth	Pitch	Major Diameter	Form Diameter	Minor Diameter	Minor Diameter									
D	14	12/24	1.248/1.247	1.07	1.063/1.050	Major dia. fit									

4535VQH INSTALLATION DIMENSION

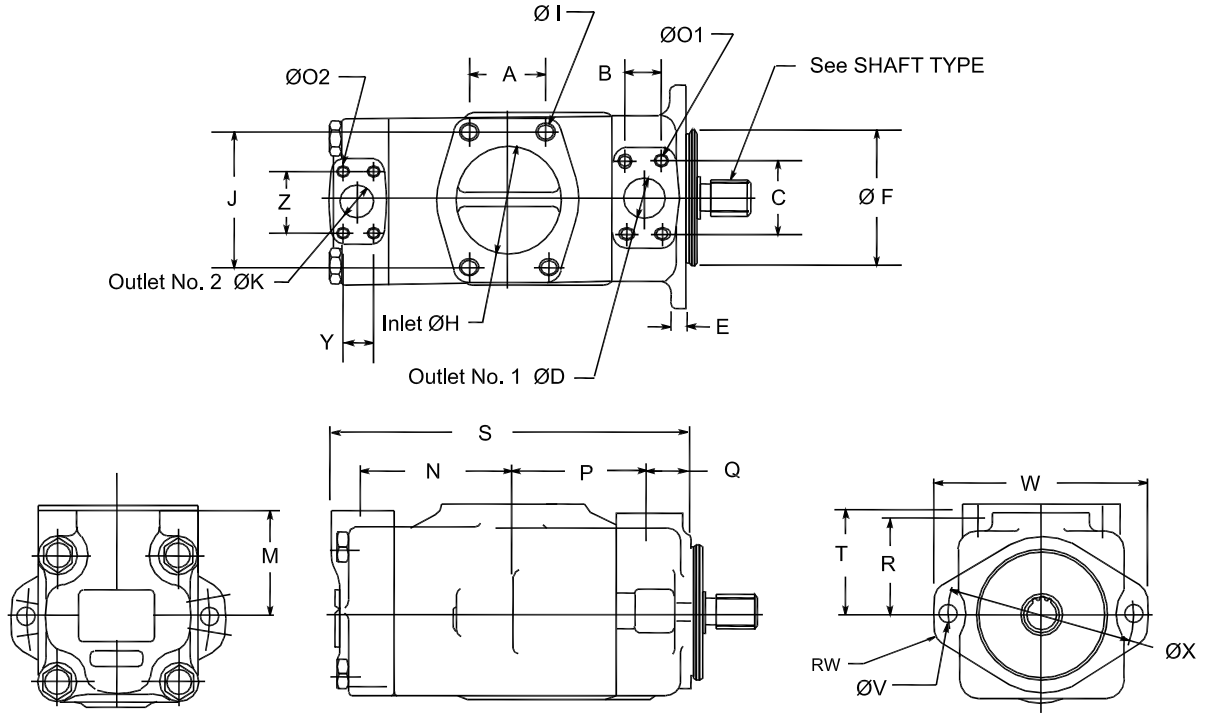

SHAFT TYPE

#1 Straight Shaft

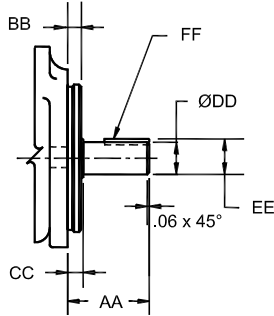

#11 Splined Shaft

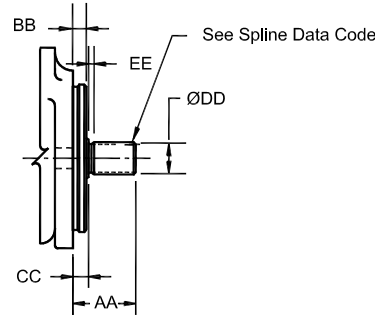

#86 Straight Shaft

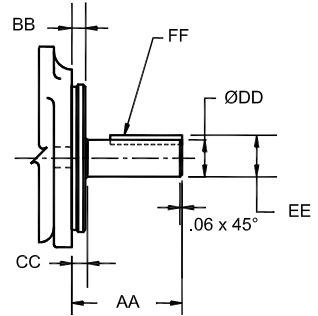

	A	B	C	øD	E	øF	øH	J	øK	M	N	P	Q	R	
BODY	3.06	1.41	2.75	1.50	0.62	5.000/4.998	4.00	5.13	1.25	4.00	5.84	5.25	1.69	3.69	
	S	T	øV x 2	RW	W	øX	Y	Z							
	13.9	4.03	0.69	0.63	8.38	7.13	1.19	2.31							
PORT CONN.	ØO1 x 4 Holes			ØO2 x 4 Holes			Ø I x 4 Holes			Outlet No 1 Flange		Outlet No 2 Flange		Inlet Flange	
	1/2"-13UNC-2B x 0.94			7/16"-14UNC-2B x 0.88			5/8"-11UNC-2B x 1.25			F1-12-		F1-10-		F1-32-	
SHAFT TYPE	Shaft Type	AA	BB	CC	øDD	EE	FF Key Width x Length								
	1	2.44	.500	.560	1.250/1.248	1.390/1.380	.312x1.12								
	86	3.44	.500	.560	1.499/1.498	1.669/1.659	.375x2.00								
	Shaft Type	AA	BB	CC	øDD	EE	Spline Data Code								
11	2.44	.500	.565	1.56	.38	D (See Below Chart)									
Spline Data Code	Number of Teeth	Pitch	Major Diameter	Form Diameter	Minor Diameter	Minor Diameter									
D	14	12/24	1.248/1.247	1.07	1.063/1.050	Major dia. fit									

(F3) - V10 1 S 5 S - 1 C 22 L

 1 2 3 4 5 6 7 8 9 10

1 Special Seals

Omit - (Standard)
 F3 - Viton Seals

2 Series No

V10 V20

3 Mounting

1 - 2-Bolt Flange (Standard)

4 Inlet Port Connection

S - (Standard)

1 5/16-12 UN-2B (V10 Only)

1 5/8-12 UN-2B (V20 Only)

P - 1" NPT (V10 Only)

1 1/4" NPT (V20 Only)

5 Pump (GPM)

(@1200 RPM, 100 PSI)

V10

V20

1

6

2

7

3

8

4

9

5

11

6

12

7

13

6 Outlet Port Connection

S - (Standard)

3/4-16 UNF-2B (V10 Only)

1 1/16-12 UN-2B (V20 Only)

P - 1/2" NPT (V10 Only)

3/4" NPT (V20 Only)

7 Shaft Type

1 - Straight Keyed (Standard)

11 - Splined

62 - Splined (V20 Only)

8 Outlet Port Position

(View From Cover End of Pump)

A - Opposite Inlet

B - 90° CCW From Inlet

C - Inline With Inlet (Standard)

D - 90° CW From Inlet

9 Design Number

22 - (Standard)

10 - Design Change

10 Rotation

(View From Shaft End of Pump)

Omit - Right Hand Rotation

(Standard)

L - Left Hand Rotation



SERIES NO	PUMP (GPM)	MAX SPEED (RPM)			MAX PRESSURE (PSI)		
		ANTI-WEAR OIL	WATER GLYCOL	WATER-IN-OIL EMULSION	ANTI-WEAR OIL	WATER GLYCOL	WATER-IN-OIL EMULSION
V10	1	4800	1800	1800	2500	1800	1500
	2	4500					
	3	4000					
	4	3400			2200		
	5	3200					
	6	3000					
	7	2800					
V20	6	3400	2500	1575			
	7	3000					
	8	2800					
	9						
	11	2500	2200		1575	1350	
	12	2400					
13							

(F3) - V2010 1 F 13 S 3 S - 1 C C 22 L

 1 2 3 4 5 6 7 8 9 10 11 12 13

1 Special Seals

Omit - (Standard)
 F3 - Viton Seals

2 Series No

V2010 V2020

3 Mounting

1 - 2-Bolt Flange (Standard)

4 Inlet Port Connection

F - SAE 4-Bolt Flange (Standard)

5 Shaft End Pump (GPM)

(@1200 RPM, 100 PSI)
 V20** - 6, 7, 8, 9, 11, 12, 13

6 Outlet No 1 Port Connection

S - 1 1/16-12 UN-2B (Standard)

7 Cover End Pump (GPM)

(@1200 RPM, 100 PSI)
 V**10 V**20

1 6

2 7

3 8

4 9

5 11

6

7

8 Outlet No 2 Port Connection

S - 3/4-16 UNF-2B (V2010 Only)
 1 1/16-12 UN-2B (V2020 Only)

9 Shaft Type

1 - Straight Keyed (Standard)

11 - Splined

10 Outlet No 1 Port Position

(View From Cover End of Pump)

A - Opposite Inlet

B - 90° CCW From Inlet

C - Inline With Inlet (Standard)

D - 90° CW From Inlet

11 Outlet No 2 Port Position

(View From Cover End of Pump)
 V2010

A - 135° CCW From Inlet

B - 45° CCW From Inlet

C - 45° CW From Inlet (Standard)

D - 135° CW From Inlet

V2020

A - Opposite Inlet

B - 90° CCW From Inlet

C - Inline With Inlet (Standard)

D - 90° CW From Inlet

12 Design Number

22 - (Standard)

10 - Design Change

13 Rotation

(View From Shaft End of Pump)

Omit - Right Hand Rotation

(Standard)

L - Left Hand Rotation



SERIES NO	V20** (FOR V2010 & V2020)			V**10 (FOR V2010)			V**20 (FOR V2020)			
	PUMP CODE	MAX SPEED (RPM)	MAX PRESSURE (PSI)	PUMP CODE	MAX SPEED (RPM)	MAX PRESSURE (PSI)	PUMP CODE	MAX SPEED (RPM)	MAX PRESSURE (PSI)	
V2010 V2020	6	3000	2500	1	3000	2500	6	3000	2500	
	7			2			7			
	8			3			8			
	9	2800		4			9	2800		
	11	2500		5			11	2500		
	12	2400		2200			6	2800		2200
	13						7			2000

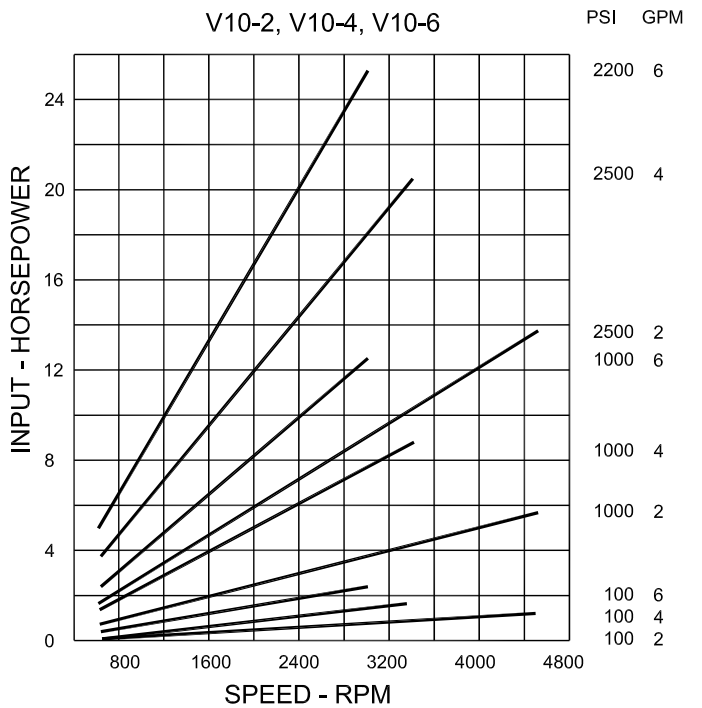
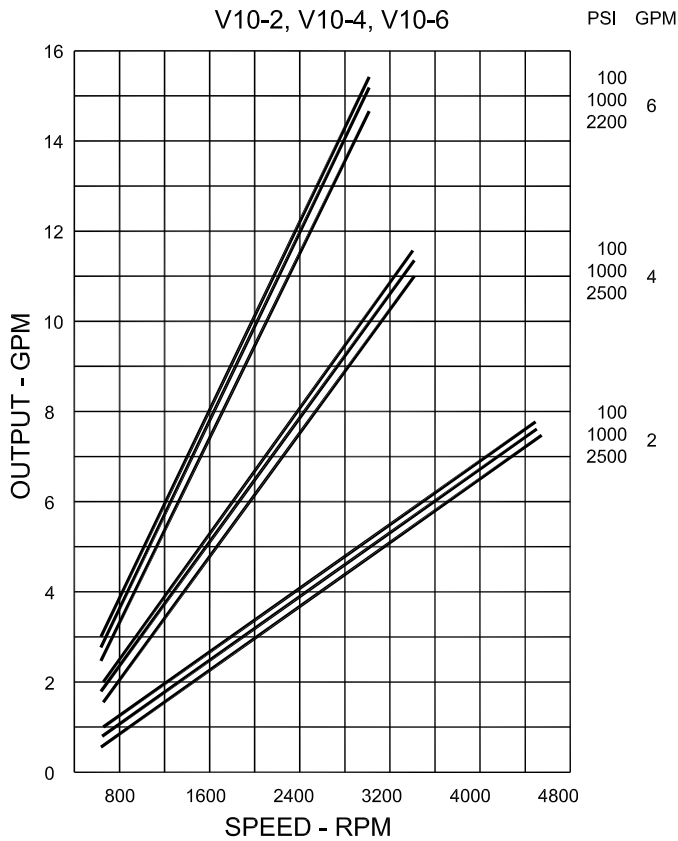
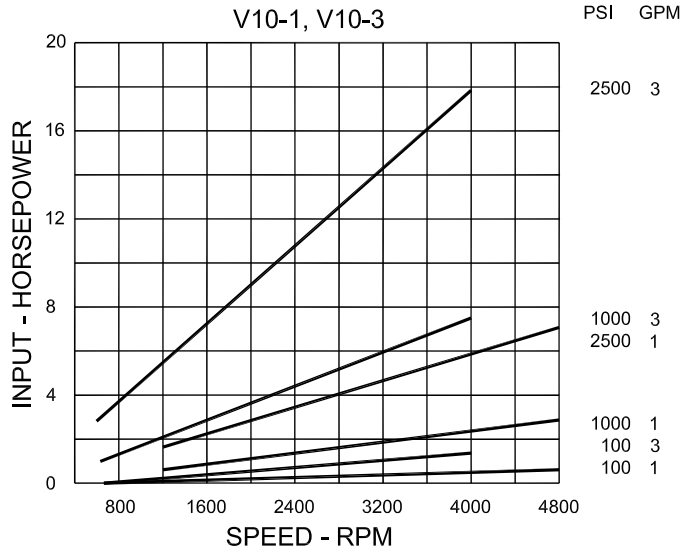
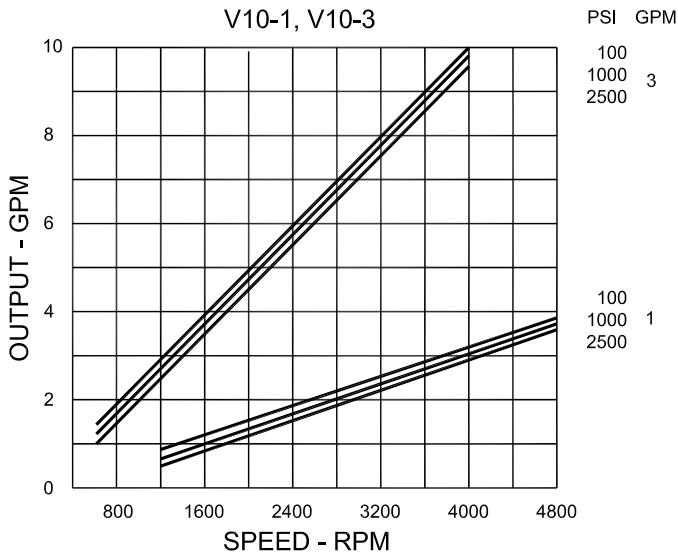

Data Based on Oil Temperature @ 120°F and Pump Inlet @ 0 PSIG (14.7 PSIA)

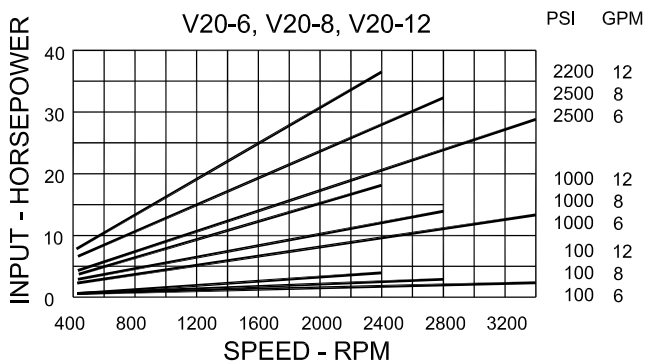
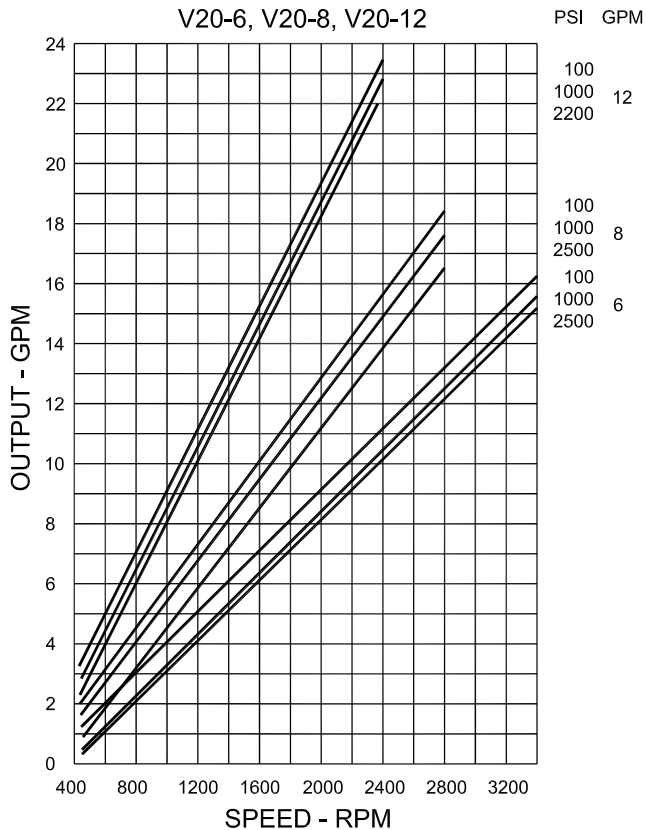
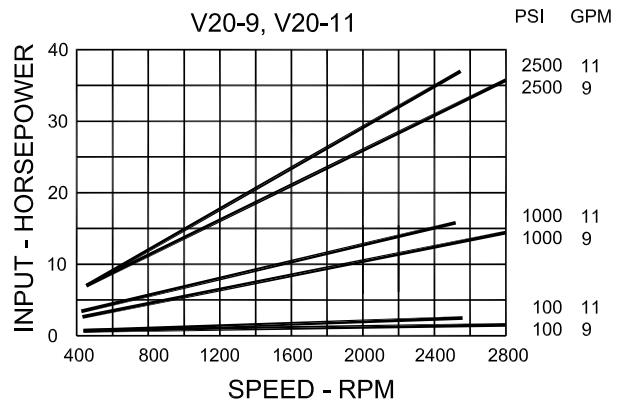
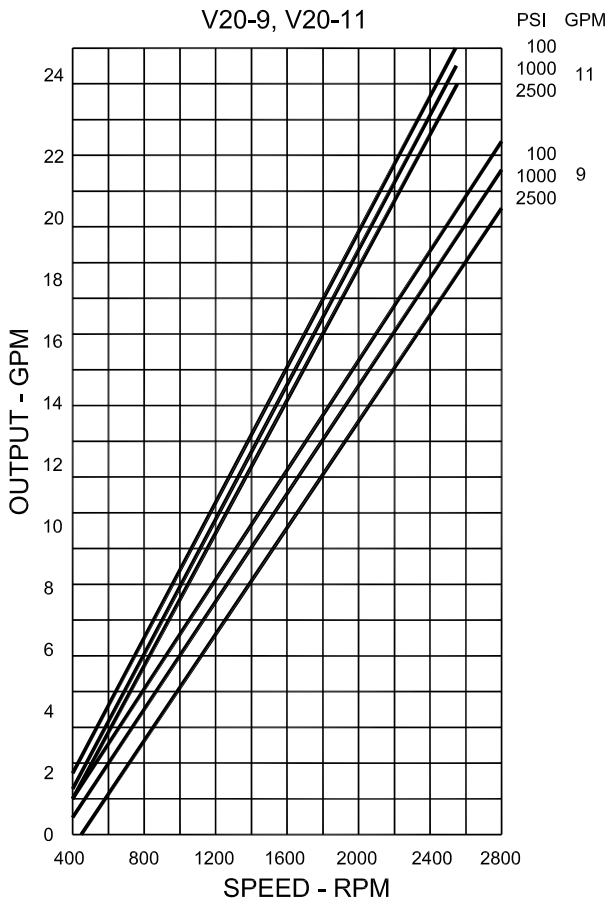

Data Based on Oil Temperature Fluid @ 120°F and Pump Inlet @ 0 PSIG (14.7 PSIA)

Data Based on Oil Temperature @ 120°F and Pump Inlet @ 0 PSIG (14.7 PSIA)

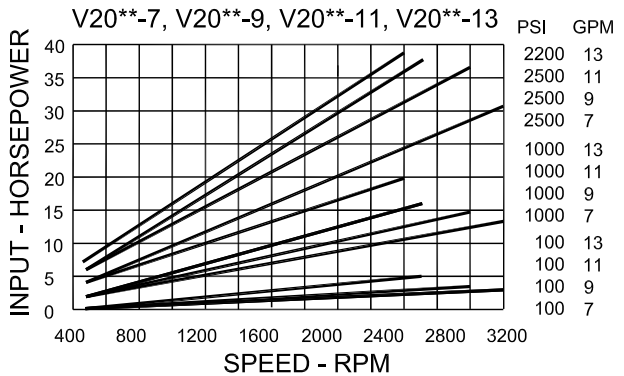
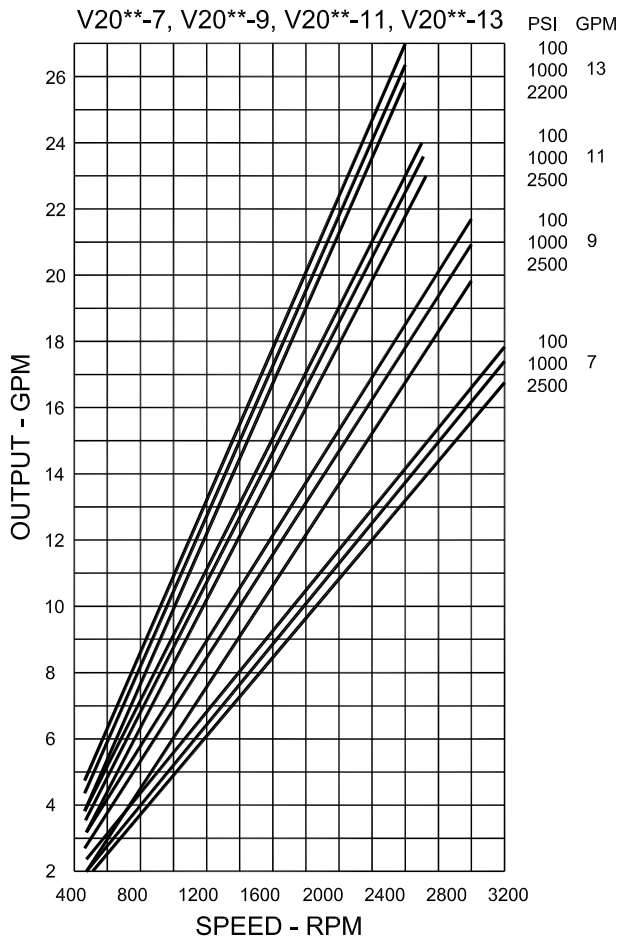
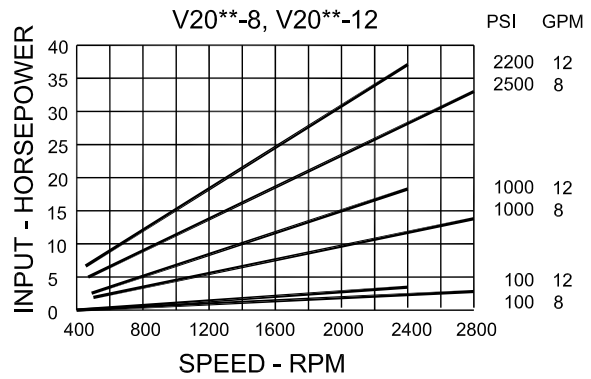
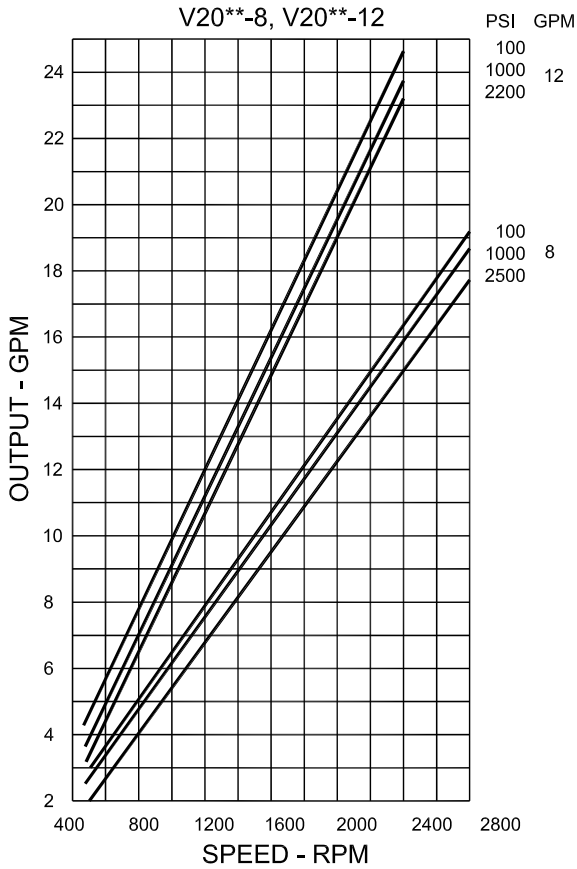

Data Based on Oil Temperature @ 120°F and Pump Inlet @ 0 PSIG (14.7 PSIA)

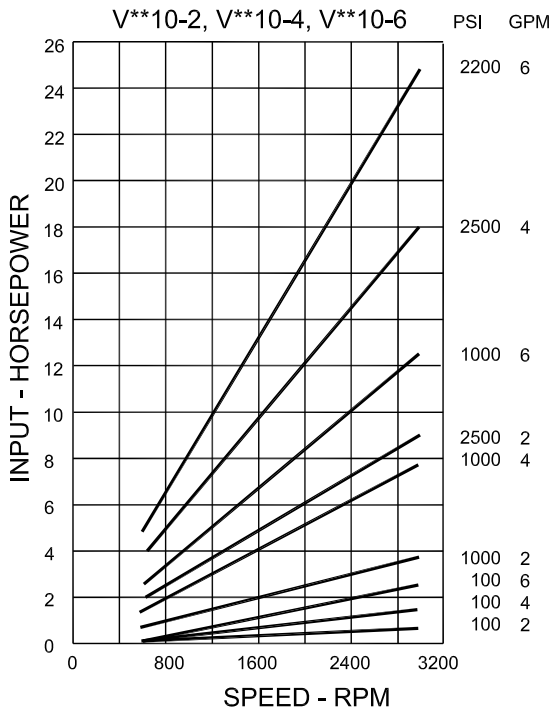
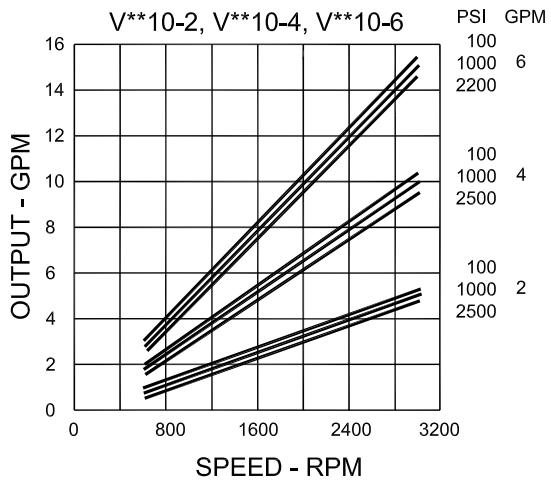
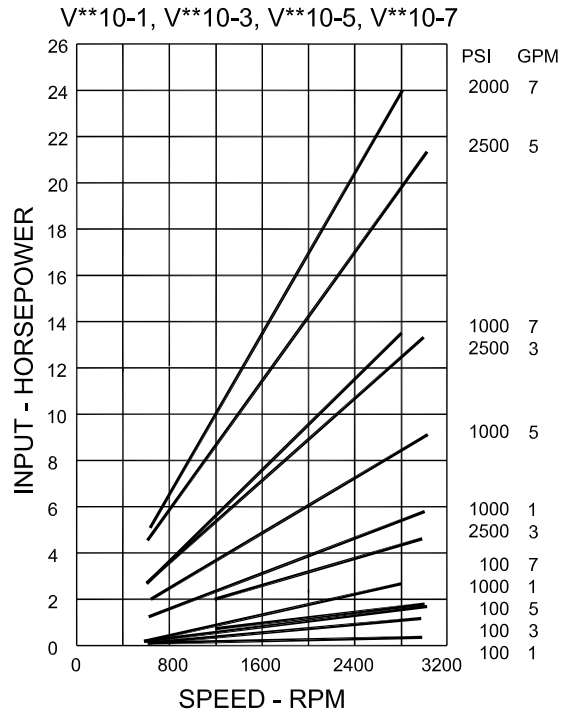
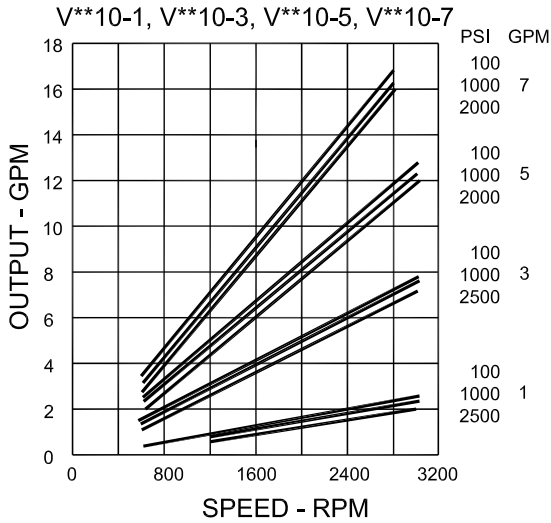

Data Based on Oil Temperature @ 120°F and Pump Inlet @ 0 PSIG (14.7 PSIA)

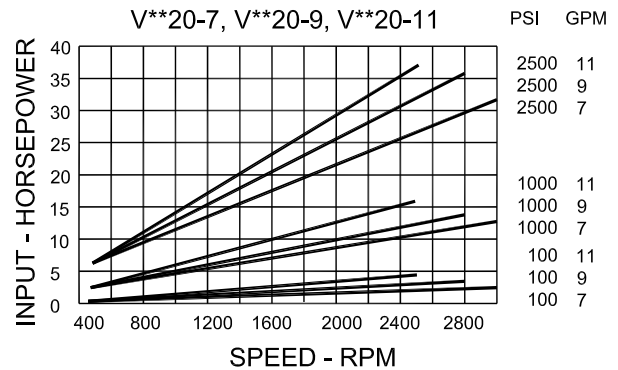
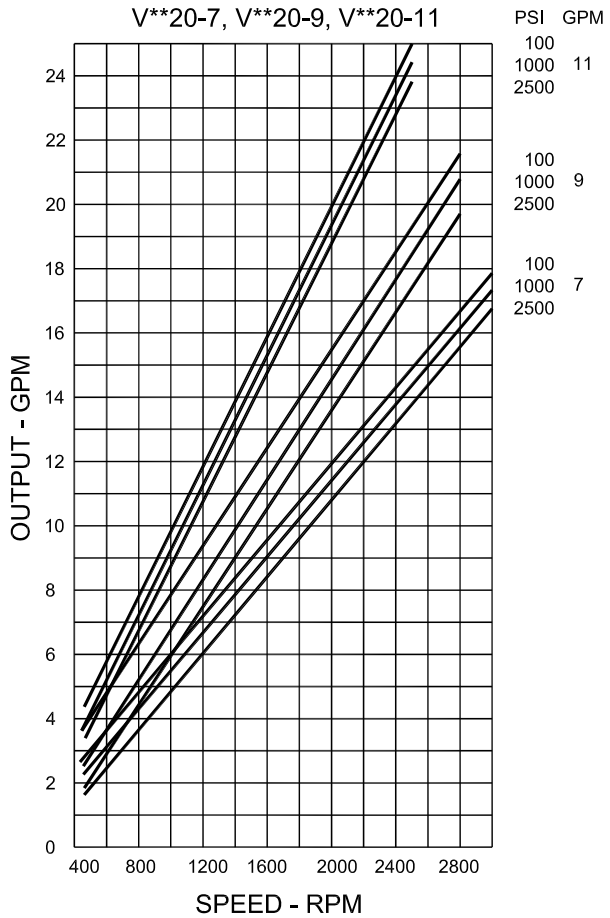
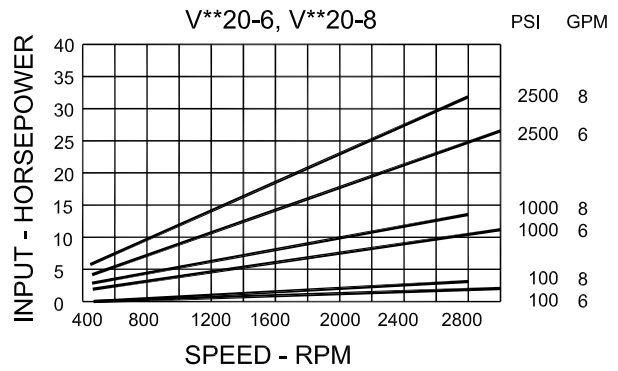
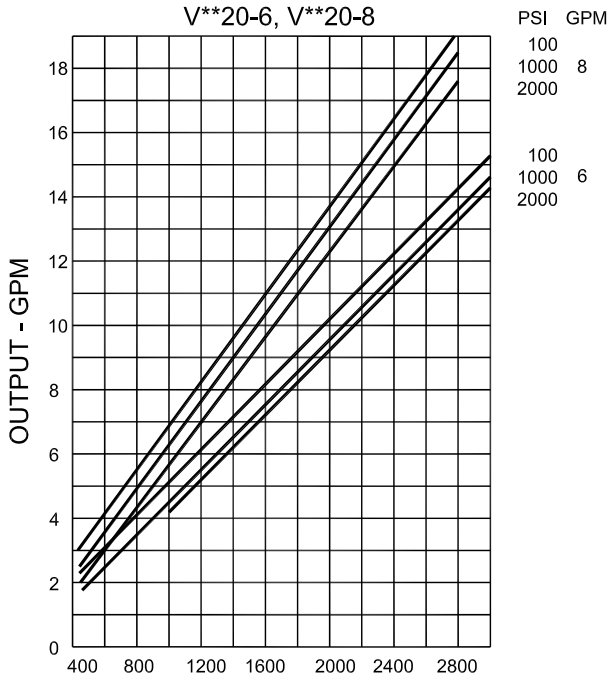

V10 INSTALLATION DIMENSION

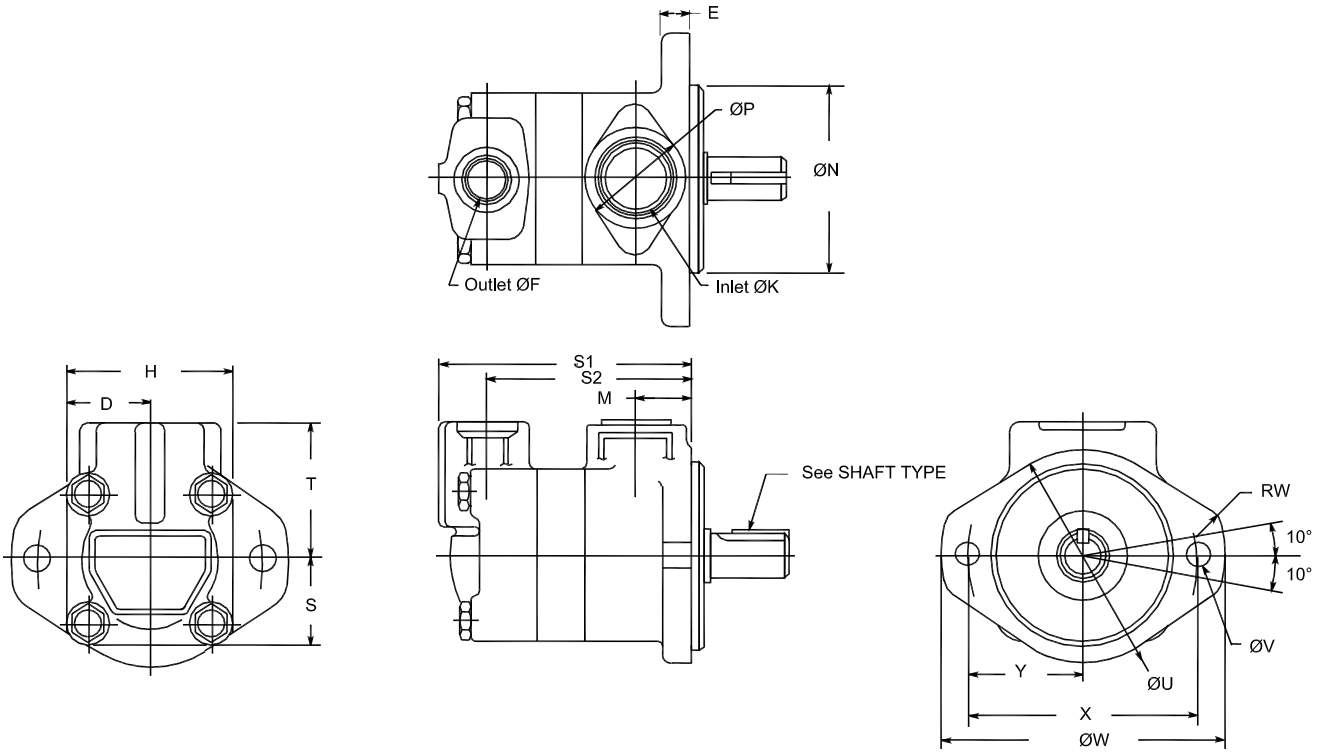

SHAFT TYPE

#1 Straight Shaft

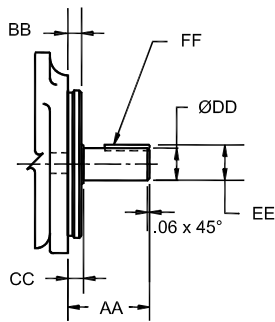

#11 Splined Shaft

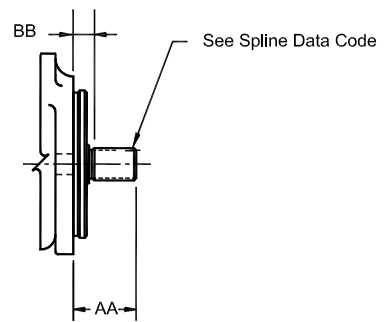

BODY	D	E	H	M	øN	ØP	T	S	RW	øU	ØV x 2	ØW	X	Y			
	1.50	0.50	3.00	0.97	3.250/3.248	1.81	2.47	1.50	0.47	3.75	0.437	5.12	4.19	2.09			
											V10 (GPM)		1,2,3		4,5		6,7
										S1	S2	S1	S2	S1	S2		
										4.55	3.62	4.80	3.87	5.00	4.07		

PORT CONN.	Outlet ØF	Inlet øk
	3/4"-16UNF-2B or 1/2" NPT	1 5/16"-12UNF-2B or 1" NPT

SHAFT TYPE	Shaft Type	AA	BB	CC	øDD	EE	FF Key Width x Length
	1	1.75	.250/.240	.31	.750/.749	.832/.827	.187x1.00
	11	1.25	.58	Spline Data Code G (See Below Chart)			
	Spline Data Code	Number of Teeth	Pitch	Major Diameter	Pitch Diameter	Minor Diameter	Minor Diameter
	G	9	16/32	.623/.622	.5625	.4835/.4725	Major dia. fit

V20 INSTALLATION DIMENSION

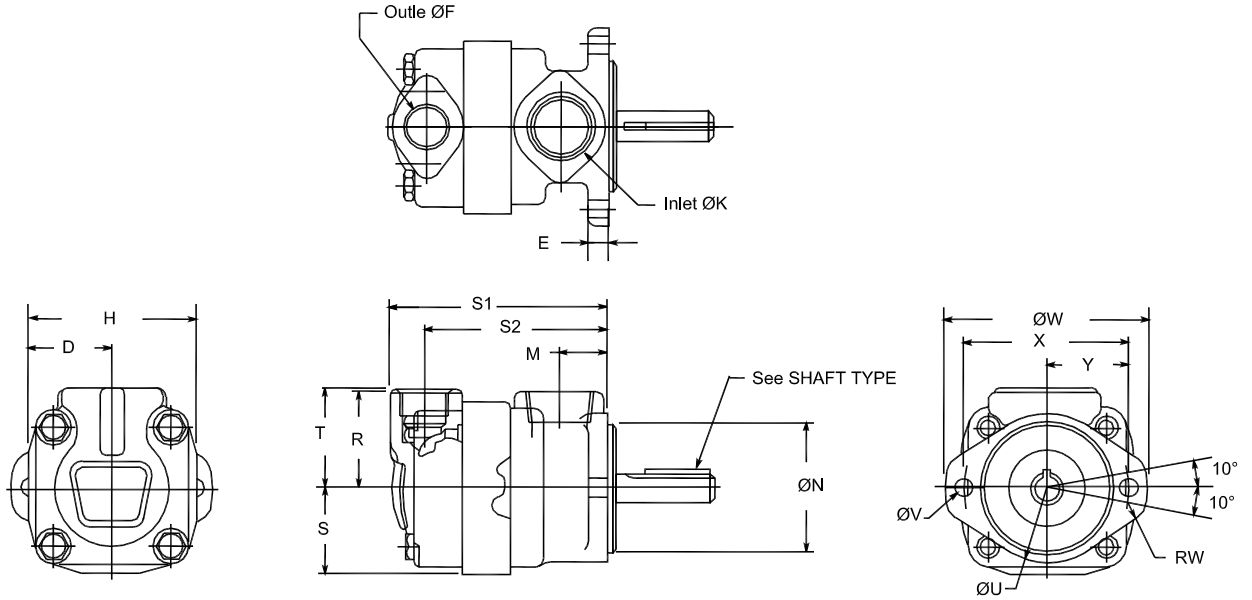

SHAFT TYPE

#1 Straight Shaft

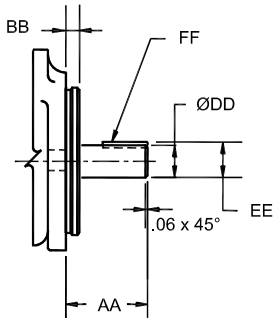

#11 Splined Shaft

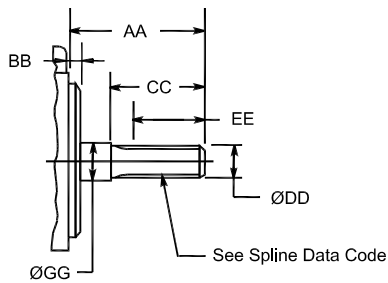

#62 Splined Shaft

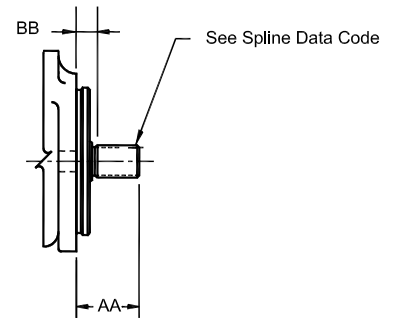

BODY

D	E	H	M	øN	S	T	R	RW	øU	øV x 2	øW	X	Y	
2.19	0.50	4.38	1.22	3.250/3.248	2.19	2.60	2.44	0.47	3.75	0.437	5.12	4.19	2.09	
					V20 (GPM)		6		7,8,9		11		12,13	
							S1	S2	S1	S2	S1	S2	S1	S2
							4.93	4.02	5.18	4.27	5.38	4.47	5.52	4.61

PORT
CONN.

Outlet ØF	Inlet øk
1 1/16"-12 UN-2B or 3/4" NPT	1 5/8"-12UN-2B or 1 1/4" NPT

SHAFT
TYPE

Shaft Type	AA	BB	ØDD	EE	FF Key Width x Length		
1	2.66	.156	.750/.749	.832/.827	.1875x1.62		
Shaft Type	AA	BB	CC	ØDD	EE	GØG	Spline Data Code
11	2.94	.156	2.00	.751/.749	1.47	.751/.749	F (See Below Chart)
62	1.25	.58					G (See Below Chart)
Spline Data Code	Number of Teeth	Pitch	Major Diameter	Pitch Diameter	Minor Diameter	Minor Diameter	Pressure Angle
F	11	16/32					30°
G	9	16/32	.623/.622	.5625	.4835/.4725	Major dia. fit	

V2010 INSTALLATION DIMENSION

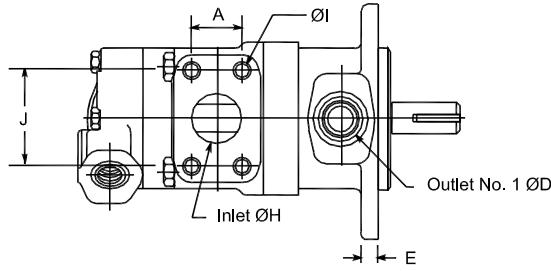

VIEW V1-V1

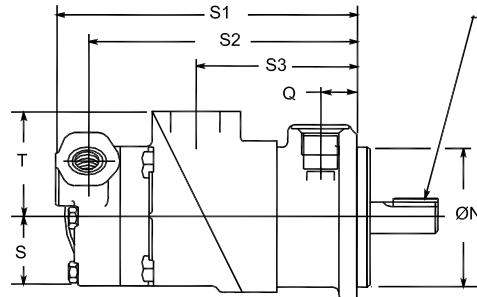
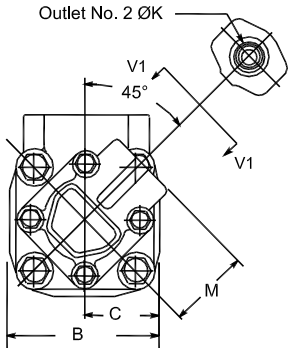

See SHAFT TYPE

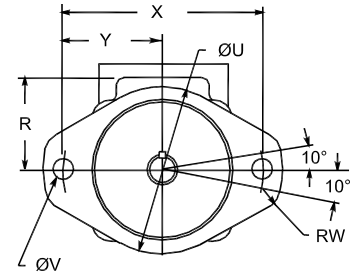

SHAFT TYPE

#1 Straight Shaft

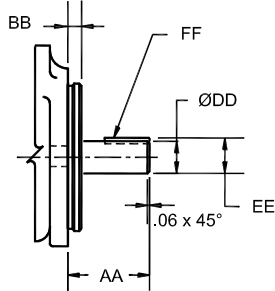

#11 Splined Shaft

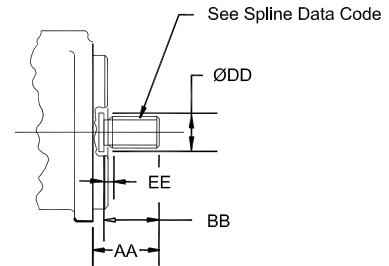

	A	B	C	E	ØH	J	M	ØN	Q	S	T	R	RW	ØU							
	2.00	4.38	2.19	0.50	1.50	3.50	2.38	4.000/3.998	1.06	2.00	3.00	2.62	0.56	4.75							
BODY					V20** (GPM)		V**10 (GPM)		V20** (GPM)		V**10 (GPM)		V20** (GPM)		V**10 (GPM)						
					7,8,9		1,2,3		7,8,9		4,5		7,8,9		6,7						
	ØV x 2	X	Y			S1	S2	S3	S1	S2	S3	S1	S2	S3	S1	S2	S3				
	0.56	5.75	2.88			8.39	7.45	4.46	8.64	7.70	4.46	8.84	7.90	4.46	8.59	7.65	4.65				
				V20** (GPM)		V**10 (GPM)		V20** (GPM)		V**10 (GPM)		V20** (GPM)		V**10 (GPM)		V20** (GPM)		V**10 (GPM)			
				11		4,5		11		6,7		12,13		1,2,3		12,13		4,5			
				S1		S2		S3		S1		S2		S3		S1		S2		S3	
				8.84		7.90		4.65		9.04		8.10		4.79		8.73		7.79		4.79	

PORT CONN.	Outlet No 1 ØD	Outlet No 2 ØK	ØI x 4 Holes	Inlet Flange
	1 1/16"-12 UN-2B	3/4"-16 UNF-2B	1/2"-13 UNC-2B x 0.88	F1-12-

SHAFT TYPE	Shaft Type	AA	BB	ØDD	EE	FF Key Width x Length
	1	2.32	.375	.875/.874	.996/.961	.1875x1.25

SHAFT TYPE	Shaft Type	AA	BB	ØDD	EE	Spline Data Code	
	11	1.62	1.31	1.15	.16	A (See Below Chart)	
	Spline Data Code	Number of Teeth	Pitch	Major Diameter	Form Diameter	Minor Diameter	Minor Diameter
	A	13	16/32	.873/.872	.749	.734/.723	Major dia. fit

V2020 INSTALLATION DIMENSION

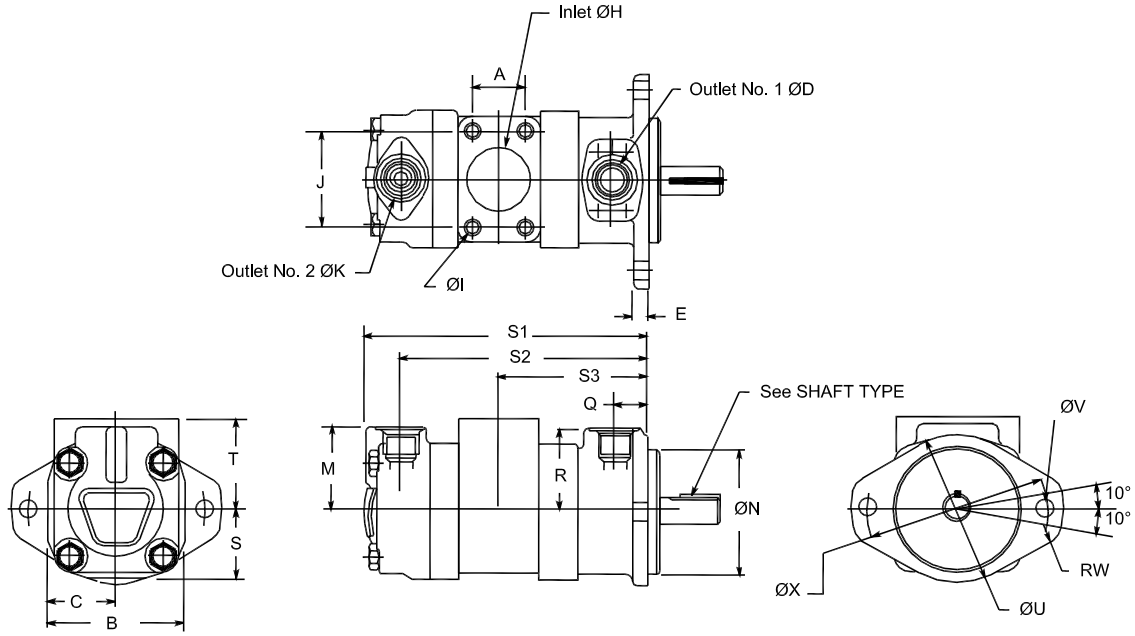

SHAFT TYPE

#1 Straight Shaft

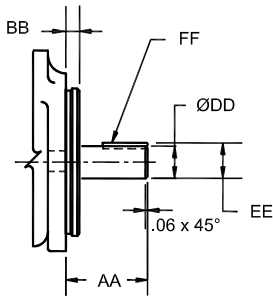

#11 Splined Shaft

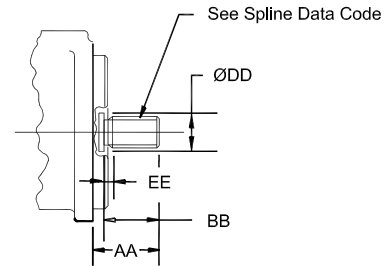

	A	B	C	E	ØH	J	M	ØN	Q	S	T	R	RW	ØU		
	1.69	4.38	2.19	0.50	1.94/2.00	3.06	2.75	4.000/3.998	1.06	2.19	2.94	2.62	0.56	4.75		
BODY					V20** (GPM)		V**20 (GPM)		V20** (GPM)		V**20 (GPM)		V20** (GPM)		V**20 (GPM)	
					7,8,9		6		7,8,9		7,8,9		11		6	
	ØV x 2 ØX				S1 S2 S3		S1 S2 S3		S1 S2 S3		S1 S2 S3		S1 S2 S3		S1 S2 S3	
	0.56 5.75				8.41 7.39 4.49		8.66 7.64 4.49		8.61 7.59 4.69		8.86 7.84 4.69					
				V20** (GPM)		V**20 (GPM)		V20** (GPM)		V**20 (GPM)		V20** (GPM)		V**20 (GPM)		
				11		11		12,13		6		12,13		7,8,9		
				S1 S2 S3		S1 S2 S3		S1 S2 S3		S1 S2 S3		S1 S2 S3		S1 S2 S3		
				9.05 8.03 4.69		8.75 7.73 4.82		8.99 7.97 4.82		9.19 8.17 4.82						

PORT CONN.	Outlet No 1 ØD	Outlet No 2 ØK	ØI x 4 Holes	Inlet Flange
	1 1/16"-12 UN-2B	1 1/16"-12 UN-2B	1/2"-13 UNC-2B x 0.94	F1-16-

SHAFT TYPE	Shaft Type	AA	BB	ØDD	EE	FF Key Width x Length	
		1	2.32	.37	.875/.874	.996/.961	.1875x1.25
SHAFT TYPE	Shaft Type	AA	BB	ØDD	EE	Spline Data Code	
		11	1.62	1.31	1.15	.16	A (See Below Chart)
SHAFT TYPE	Spline Data Code	Number of Teeth	Pitch	Major Diameter	Form Diameter	Minor Diameter	Minor Diameter
	A	13	16/32	.873/.872	.749	.734/.723	Major dia. fit

SAE 4-Bolt Flange

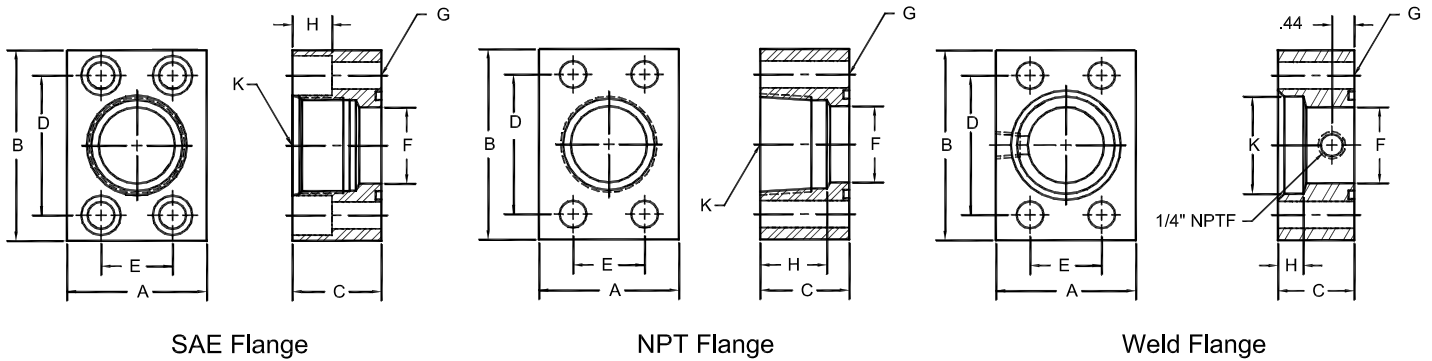

SAE Straight Threaded	Flange Size	A	B	C	D	E	F	G	H	K	BOLT SIZE ①
F1-6-S	3/4	1.75	2.62	1.5	1.875	0.875	0.75	0.41	0.59	1 1/16-12	3/8-16 x 1 1/2
F1-8-S	1	2	2.82	1.5	2.062	1.031	1	0.41	0.59	1 5/16-12	3/8-16 x 1 1/2
F1-10-S	1 1/4	2.5	3.19	1.5	2.312	1.188	1.25	0.47	0.71	1 5/8-12	7/16-14 x 1 1/2
F1-12-S	1 1/2	2.75	3.75	1.75	2.75	1.406	1.5	0.53	0.78	1 7/8-12	1/2-13 x 1 3/4

NPTF Pipe Threaded	Flange Size	A	B	C	D	E	F	G	H	K (NPTF)	BOLT SIZE ①
F1-6-P	3/4	1.75	2.62	1.25	1.88	0.88	0.75	0.41	1.06	3/4	3/8-16 x 2
F1-8-P	1	2.00	2.82	1.50	2.06	1.03	1.00	0.41	1.25	1	3/8-16 x 2 1/4
F1-10-P	1 1/4	2.50	3.19	1.50	2.31	1.19	1.25	0.47	1.31	1 1/4	7/16-14 x 2 1/4
F1-12-P	1 1/2	2.75	3.75	1.75	2.75	1.41	1.50	0.53	1.31	1 1/2	1/2-13 x 2 1/2
F1-16-P	2	3.25	4.00	1.75	3.06	1.69	1.94	0.53	1.31	2	1/2-13 x 2 1/2
F1-20-P ②	2 1/2	4.00	4.50	2.00	3.50	2.00	2.44	0.53	1.75	2 1/2	1/2-13 x 2 3/4
F1-24-P ③	3	4.50	5.50	2.25	4.19	2.44	2.94	0.66	2.00	3	5/8-11 x 3 1/2

Pipe Welded	Flange Size	A	B	C	D	E	F	G	H	K	BOLT SIZE ①
F1-8-W	1	2.00	2.82	1.25	2.062	1.031	1.00	0.41	0.50	1.335	3/8-16 x 2
F1-10-W	1 1/4	2.50	3.19	1.25	2.312	1.188	1.25	0.47	0.50	1.680	7/16-14 x 2
F1-12-W	1 1/2	2.75	3.75	1.25	2.750	1.406	1.50	0.53	0.50	1.920	1/2-13 x 2
F1-16-W	2	3.25	4.00	1.50	3.062	1.688	1.94	0.53	0.62	2.411	1/2-13 x 2 1/4
F1-20-W ②	2 1/2	4.00	4.50	1.75	3.500	2.000	2.44	0.53	0.75	2.911	1/2-13 x 2 1/2
F1-24-W ③	3	4.50	5.31	2.00	4.188	2.438	2.94	0.66	0.75	3.540	5/8-11 x 3
F1-28-W ④	3 1/2	5.00	6.00	1.50	4.750	2.750	3.44	0.66	0.75	4.045	5/8-11 x 2 1/2
F1-32-W ④	4	5.50	6.38	1.50	5.125	3.062	3.94	0.66	0.75	4.550	5/8-11 x 2 1/2

- ① Order Separately
- ② 2500 PSI Max
- ③ 2000 PSI Max
- ④ 500 PSI Max



Scenery Hydraulic, Inc.

1939 S. Lake Place

Ontario, CA 91761

Tel: (909)930-9586

Fax: (909)354-3181

Email: sales@sceneryhydraulic.com

www.sceneryhydraulic.com